

Electromagnetic Wave Simulation in Fusion Plasmas

O. Meneghini*, S. Shiraiwa

MIT-Plasma Science and Fusion Center

*Corresponding author: 77 Massachusetts Avenue, orso@mit.edu

Abstract: COMSOL has been used to model the propagation of electromagnetic waves in fusion plasmas. For the first time, a finite element method has been used to solve the wave propagation for realistic fusion plasma parameters in the lower hybrid and ion cyclotron frequency ranges. Moreover, for lower hybrid waves, a new efficient iterative algorithm has been developed to take into account the dispersive effects of a hot plasma. The advantages of the finite element method approach include a significant reduction of computational requirements compared to full wave spectral methods and a more accurate description of the antenna geometry, while seamlessly handling the plasma region.

Keywords: Electromagnetic, plasma, fusion, lower hybrid, ion cyclotron

1. Introduction

Fusion is a form of nuclear energy which has impressive advantages from the point of view of fuel reserves, environmental impact and safety. If successful, fusion energy would ensure a safe, resource conserving, environmentally friendly power supply for future generations. In a world wide cooperation to achieve this goal, seven parties including Europe, Japan, Russia, USA, China, South-Korea and India are building the ITER tokamak, an international experiment which, after 10 years of construction, will put fusion research on the way to demonstrating an energy-yielding plasma on earth.

A tokamak is a machine producing a toroidal magnetic field for confining a plasma. In an operating tokamak fusion reactor [1], part of the energy generated by fusion itself will serve to maintain the plasma temperature as fuel is introduced. However, to achieve the desired levels of fusion power output the plasma has to be heated in the startup phase to its operating temperature of greater than 10 keV (over 100 million degrees Celsius) and additional current beyond that supplied by induction must be applied.

Heating and current drive can be achieved by radio frequency waves. If electromagnetic waves have the correct frequency and polarization, their energy can be transferred to the charged particles in the plasma. In this work we focus on the propagation of electromagnetic waves in the Lower Hybrid [2,3] and Ion Cyclotron [2] frequency ranges. The wave propagation and heating process in these two frequency ranges are different, and as a result also the radiating antennas at the plasma boundaries have different features. IC antennas are composed of metal loops (called straps), and fed by coaxial power lines, while LH antennas are arrays of open-ended waveguides (called grills).

Antennas are often the components which determine the success or failure of the heating system. Fabricating and testing antennas is time consuming and costly; therefore the availability of a predictive simulation tool is very important for this class of antennas. Moreover, computer simulations are indispensable for evaluating experimental results and play a major role in understanding the physics of the processes involved.

The difficulty of simulating RF waves of fusion plasmas comes from the fact that the plasma is a medium which is inhomogeneous, anisotropic and lossy. Even worse, hot plasmas are spatially dispersive, meaning that the property of this medium is non-local.

The traditional way of simulating waves in fusion plasma is by using the ray-tracing technique which approximates the wave as a "bundle of rays". However, the ray tracing approach is known to be questionable in particular regions of plasma. This issue can be addressed by directly solving Maxwell's equations inside of the plasma region (full wave simulation).

Full wave simulations are commonly treated in the spectral domain, where spacial dispersion effects are treated more easily [4]. However spectral domain solvers represent the solution in terms of basis functions which are defined over the whole computational domain and have therefore difficulty at correctly representing the tokamak vessel or the launching antenna

structure and their use is mostly limited to the description of the core plasma.

To address all of these issues simultaneously, we developed a new full wave simulation code for LH waves, which is based on the finite element method (FEM).

2. Theory and governing equations

2.1 Cold plasma theory

To a first approximation, the electromagnetic properties of fusion plasmas can be described by the magnetized cold plasma approximation. Using the notation from Stix [2], the corresponding dielectric tensor has the form

$$\bar{\bar{\epsilon}}_{\text{cold}} = \begin{pmatrix} S & -iD & 0 \\ iD & S & 0 \\ 0 & 0 & P \end{pmatrix}$$

where we the magnetic field is considered to be in \hat{z} direction. The cold plasma dielectric tensor is anisotropic, local and Hermitian (loss-less).

Within the cold plasma approximation the wave equation is a conventional Partial Differential Equation (PDE)

$$\nabla \times \nabla \times \vec{E}(\vec{x}) + \frac{\omega^2}{c^2} \bar{\bar{\epsilon}}_{\text{cold}} \cdot \vec{E}(\vec{x}) = 0$$

There are always two roots which satisfy the cold plasma dispersion relation, which are commonly referred to as the slow and the fast wave (depending on which has the higher phase velocity).

The magnetized cold plasma theory well describes the propagation of the waves which exist within the approximation. With it a wide range of effects of interest can be well described.

However, this approximation does not model the damping of the waves, which appears as a first order correction to the cold plasma approximation. To account for the collisionless damping of the waves (e.g. Landau damping, Cyclotron damping), we need to account for the finite temperature of the plasma (hot plasma) and a kinetic treatment of the waves is necessary.

2.2 Lower Hybrid waves in a magnetized Maxwellian plasma

LH waves are plasma waves which satisfy the slow wave branch of the cold plasma dispersion relation, have a frequency which lies in between the Ion Cyclotron and the Electron Cyclotron frequency (i.e. $\omega_{ce} > \omega > \omega_{ci}$) and have $|n_z| = \left| \frac{ck_z}{\omega} \right| > 1$.

The propagation of the LH waves is well described by the magnetized cold plasma

approximation, while their absorption is governed by the electron landau damping (ELD) process. ELD is a hot plasma effect term which affects only on the component of the electric field which is parallel to the magnetic field.

$$\bar{\bar{\epsilon}}(k_z) = \bar{\bar{\epsilon}}_{\text{cold}} - i \begin{pmatrix} 0 & 0 & 0 \\ 0 & 0 & 0 \\ 0 & 0 & \epsilon_{\text{ELD}}(k_z) \end{pmatrix}$$

and for a Maxwellian plasma is described by:

$$\epsilon_{\text{ELD}}(k_z) = \sqrt{\pi} \frac{\omega_{pe}^2 \omega}{|k_z|^3 v_{th}^3} \exp\left(-\frac{\omega^2}{k_z^2 v_{th}^2}\right)$$

As it can be seen, ELD depends on the parallel wave number k_z , meaning that this effect is non-local and transforms the wave equation to the following integro-differential form:

$$\nabla \times (\nabla \times \vec{E}(\vec{x})) + \frac{\omega^2}{c^2} \left(\bar{\bar{\epsilon}}_{\text{cold}} \cdot \vec{E}(\vec{x}) - i \frac{\hat{z}}{\sqrt{2\pi}} \int \epsilon_{\text{ELD}}(z - z') E_z(z') dz' \right) = 0$$

where the integration is done along the field lines and

$$\epsilon_{\text{ELD}}(z) = \frac{1}{\sqrt{2\pi}} \int \epsilon_{\text{ELD}}(k_z) e^{-ik_z z} dk_z$$

is the Fourier transform of the $\epsilon_{\text{ELD}}(k_z)$ term.

2.3 Generalization to non-Maxwellian plasma

The presence of LH wave fields in the plasma tends to distort the electrons velocity distribution function, by pulling a tail in the parallel direction out of the Maxwellian distribution at $\frac{\omega}{k_{\parallel}} \approx 2.5v_{Te}$, where is the v_{Te}

thermal speed of the electrons. Coulomb collisions tend to restore the electron distribution function to a Maxwellian.

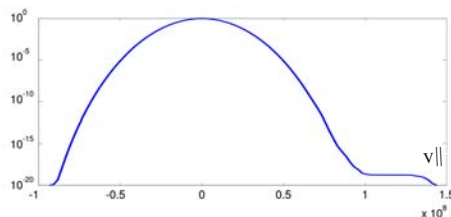

Illustration 1: Plot of the parallel distribution function, showing the characteristic tail formation as a result of the presence of LH waves in the plasma.

The formation of this tail, is what drives the toroidal current (first order moment of the distribution function) in a tokamak.

Once the parallel distribution function is evaluated, the ELD term can be computed [2] as

$$\epsilon_{\text{ELD}}(k_{\parallel}) = -\frac{\omega_{pe}^2 2\pi}{\omega^2} \int_0^{\infty} v_{\perp} dv_{\perp} \frac{\omega^2}{k_{\parallel}^2} \frac{\partial f}{\partial v_{\parallel}} \Big|_{v_{\parallel} = \frac{\omega}{k_{\parallel}}}$$

This process is obviously non-linear, since the deformed distribution function changes the form of $\epsilon_{\text{ELD}}(\vec{k})$. A correct evaluation of the distortion of the electron distribution function is hence extremely important for an accurate evaluation of the wave damping, and viceversa.

2.4 Toroidal symmetry and single toroidal mode analysis

A tokamak is a machine producing a toroidal magnetic field for confining a plasma, and is characterized by an azimuthal (rotational) symmetry. The toroidal symmetry of the device allows a Fourier analysis of the electromagnetic fields in the toroidal direction

$$\vec{E}(x, y, \phi) = \sum_{n=-\infty}^{\infty} \vec{E}_n(x, y) e^{-in_\phi \phi}$$

where n_ϕ is the toroidal mode number.

3. Methods

3.1 Modeling within the magnetized cold plasma wave theory

We exploited COMSOL unique capability of allowing the definition of the full 3D dielectric tensor of a spatially varying media to model the harmonic propagation of waves in a cold magnetized plasma. With COMSOL we were able to model the exact shape of the tokamak first wall and of the antenna launching structure. Also, the toroidal helical magnetic field topology and the plasma density were directly input from experimental measurements.

In particular we modeled the propagation of waves in the Alcator C-Mod tokamak experiment [5] for the Lower Hybrid (4.6GHz) and Ion Cyclotron (80 MHz) frequency ranges.

For the IC frequency range, we modeled for the first time in a single self-consistent simulation, the behavior of a realistic antenna geometry when facing a (cold) plasma.

For the LH frequency range, we developed a new approach to do single mode analysis in a 3D FEM solver [6] and we included the effect of electron Landau damping (an hot plasma effect) by means of an innovative iterative routine developed in MATLAB, as described in [7,8].

3.2 Single toroidal mode analysis in a 3D FEM solver

A wave with a single toroidal mode number could be launched in a tokamak geometry by an infinite number of infinitesimally thin phased waveguides. The boundary condition which is

imposed is that only a single toroidal mode number exists in the torus. In other words, the fields have an $e^{-in_\phi \phi}$ dependence.

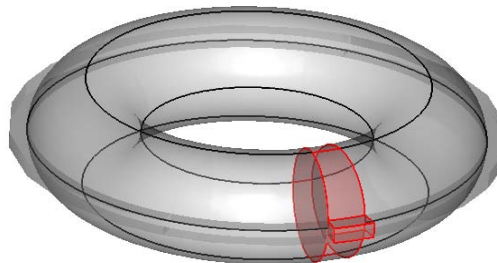

Illustration 2: Schematic of a tokamak having a circular cross section and a waveguide launching structure on the low field side. A sector including the tokamak vessel and its associated waveguide are highlighted.

Our technique exploits this simple idea to do single toroidal mode analysis in a 3D FEM solver. First we have to allow the waveguides to have a finite width. The penalty for this assumption is a small spread in the toroidal mode of the waves which are allowed to propagate inside the torus. However, as the number of waveguides increases, the spectrum of the main lobe narrows and the toroidal mode number of the side lobes increases (see figure 3). The side lobes then damp quickly in the plasma and play no role in the simulation.

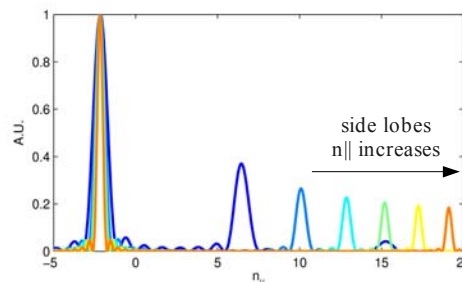

Illustration 3: The launched spectrum tends to a delta function as the angular extent of the sector becomes thinner.

We now focus our attention on one of these thin waveguides and its associated sector of the torus. If a single toroidal mode is allowed to propagate, there is a known phase relationship of $e^{-in_\phi \Delta\phi}$ between the fields at two different toroidal locations which are $\Delta\phi$ radiant apart from each other. In a 3D FEM solver, such a relationship can be imposed by applying appropriate periodic boundary conditions at the sides of the toroidal slice.

In COMSOL we implemented such custom toroidal periodic boundary conditions by means of extrusion coupling variables and perfect magnetic conductor boundary conditions. This

technique was validated using a known analytic solution, as reported in [6].

3.3 Modeling of LH waves in a hot magnetized tokamak plasma

Directly solving the original integro-differential equation corresponds to solving a large dense matrix and requires large computational power. Instead we split the problem into two coupled equations which are solved iteratively.

The main idea is that the ELD term is approximated by an effective local damping $\bar{\epsilon}_{\text{ELDeff}}^{(N)}$. The resulting equation is a conventional PDE which can be solved by a conventional 3D FEM solver. The value of the effective local damping is then found iteratively, by successive refinements of an initial guess.

According to this scheme, at the N^{th} step of the iteration loop, the electric field $\vec{E}^{(N)}(z)$ is computed by solving:

$$\nabla \times (\nabla \times \vec{E}^{(N)}(\vec{x})) + \frac{\omega^2}{c^2} (\bar{\epsilon}_{\text{cold}} + \bar{\epsilon}_{\text{LEDeff}}^{(N)}) \cdot \vec{E}^{(N)}(\vec{x}) = 0$$

Subsequently, an updated value of $\bar{\epsilon}_{\text{ELDeff}}^{(N+1)}$ is computed according to

$$\bar{\epsilon}_{\text{ELDeff}}^{(N+1)} = \frac{-i}{E^{(N)}} \frac{\hat{z} \hat{z}}{\sqrt{2\pi}} \cdot \int dz' \epsilon_{\text{ELD}}(z - z') E_z^{(N)}(z')$$

and is substituted into the conventional differential wave equation to find the electric field at the next step of the iteration. This procedure is repeated until the electric field converges.

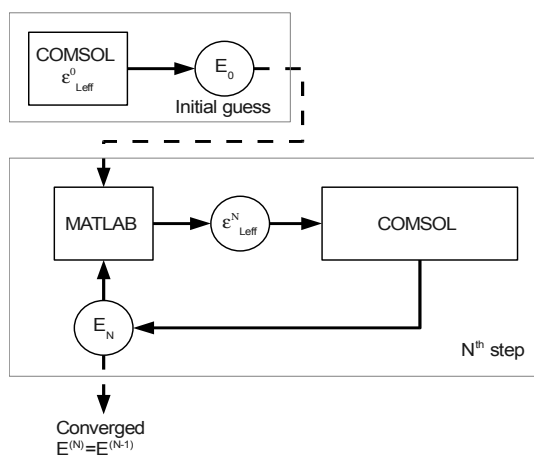

Illustration 4: Schematic of the iterative procedure, as it has been implemented using COMSOL for the solution of the wave equation and MATLAB for the evaluation of the effective local damping term $\bar{\epsilon}_{\text{ELDeff}}^{(N)}$

Our current implementation uses the RF Module of COMSOL Multiphysics and MATLAB. In this integrated environment, the former solves the EM problem at each step, while the latter calculates and sets up the iterative solution.

The non-Maxwellian electron velocity distribution arising from the interaction of the LH waves with the plasma, was taken into account by a Fokker Plank code which was included in the iteration loop. The 1DFP code was integrated in our approach by updating the parallel distribution function at each step of the ELD iteration, before the effective local damping is calculated.

3.4 Solution of large LH waves problems

FEM methods lead to the inversion of sparse matrices. In the case of electromagnetic waves propagating into an anisotropic medium (the magnetized plasma) the resulting linear system is complex and non-symmetric.

In the particular case of LH waves, the wavelength arising from the propagation in a plasmas is rather short (~mm) compared to the device size (~m), thus making the electromagnetic problem very large. Consequently in general these models require a large number of DOF for the wave fields to be solved correctly.

When doing single toroidal mode analysis in COMSOL we generally use a single mesh element to discretize the infinitesimally thin sector in the toroidal direction. Since the relationship between the solution on the two sides of the slice is known, the 3D problem effectively reduces to a 2D problem, meaning that the number of unknowns is almost cut in half.

A common way to address the solution of large sparse linear systems is to use iterative techniques. However the linear system we have to invert is very ill conditioned (also due to the high contrast of refractive index) thus making the convergence rate very slow. Also, it is known that iterative solvers do not converge when periodic boundary conditions are present. For these reasons we opted for a direct solution of the linear system for single toroidal mode analysis problems.

Models with up to 15E6 unknowns were successfully solved on a desktop computer equipped with 96GB of RAM. Models with more than 25E6 unknowns were solved by the aid of the MUMPS library [9], using the massive parallel computing resources at NERSC [10].

4. Results

First we present the simulation of ICRF and LH structures as they are radiating in a cold magnetized plasma. These simulations allow the antenna-plasma coupling and the spectrum launched into the plasma to be evaluated. Second, we present the single toroidal mode simulation of LH waves as they propagate in a toroidal cross section of the Alcator C-Mod tokamak. For this simulation the hot plasma effects are retained through the iterative routine that we introduced in section 3.3.

4.1 Simulation of 3D structures in a cold magnetized plasma

Presented below is the simulation of a realistic ICRF geometry as it radiates at 80 MHz in a cold magnetized plasma. Figure 5 shows a snapshot of the right hand polarized electric field. The radiating straps (depicted in yellow) are hosted in a cavity (wire-framed) which is recessed from the plasma column. The wave absorption was introduced by adding a finite conductivity in the core of the plasma.

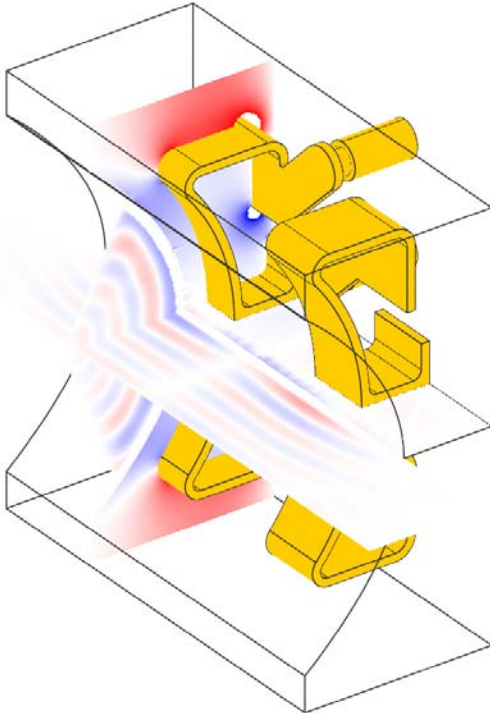

Illustration 5: Snapshot of the right hand polarized electric field of the ICRF waves as they are radiated from the antenna and they propagate in a section of the Alcator C-Mod tokamak.

Following is the simulation of a simplified LH launcher as it radiates at 4.6 GHz in a cold magnetized plasma. The launcher is composed of an array of eight phased waveguides. Each waveguide has dimensions 60x5.5mm, and is separated from the adjacent ones by 2mm septa. For this simulation the plasma is modeled as a slab, the magnetic field is purely toroidal, and a linear density profiles is used. The wave absorption was introduced by adding a finite conductivity in the core of the plasma.

Figure 6 shows a snapshot of the parallel electric field when the phase difference between adjacent columns is $\pi/2$.

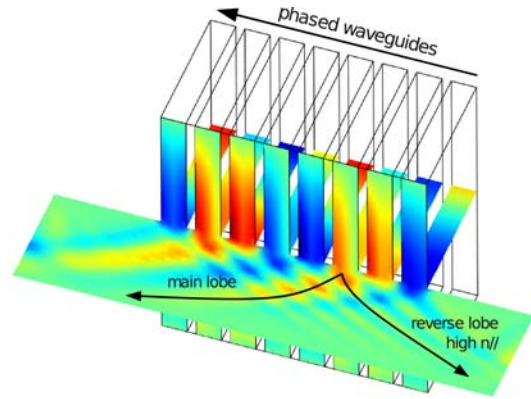

Illustration 6: Snapshot of parallel electric field of LH waves. The resonance cones which are characteristic of LH waves are clearly visible.

Figure 7 shows the corresponding launched parallel power spectrum, as evaluated by taking the two dimensional Fourier transform of the parallel electric field in front of the antenna. The spectrum is peaked at $n_{||0} = 2.1$.

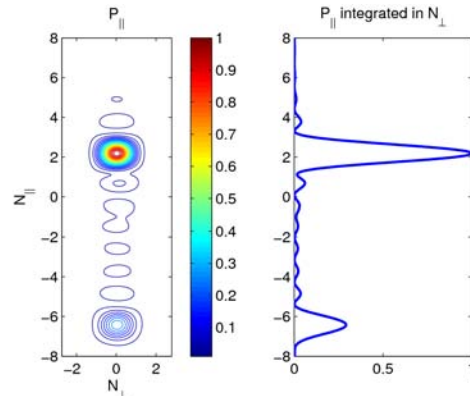

Illustration 7: Normalized parallel power spectrum launched by the eight waveguides LH launcher structure

Figure 8 presents a comparison of the coupling coefficients as computed by COMSOL

and TOPLHA [11,12] for three different phasing, showing very good agreement between the two codes.

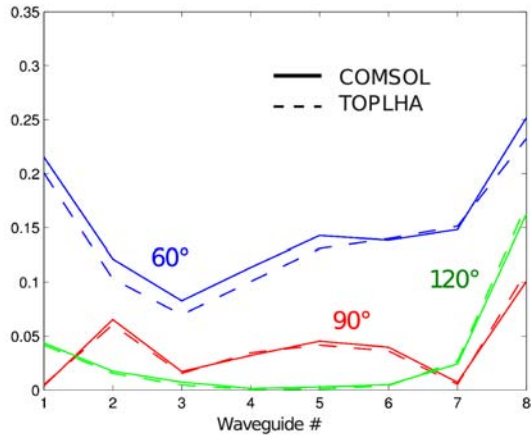

Illustration 8: Power reflection coefficient at the input of each of the eight waveguides, for progressive phasing of 60, 90 and 120 degrees.

4.2 Single toroidal mode analysis of LH waves in a hot magnetized tokamak plasma

The tokamak plasma used in the following simulation is based on the parameters of the Alcator C-Mod experiment. The computational domain is the whole tokamak cross section. The "scrape-off-layer" region, the low density plasma region surrounding the core hot plasma, which is critical for several processes involved in the LH waves physics was also included in the simulations. The results presented take into account the effect of the LH waves onto the electron distribution function. The mesh used to resolve the short perpendicular wavelength resulted in 15 million degrees of freedom.

The magnetic field of this model is based on an equilibrium reconstruction of an actual plasma of the Alcator C-Mod tokamak. The on-axis toroidal field is 5.4T, the plasma current is 1MA. The density and temperature profiles are based on the measurements of the Thompson scattering diagnostic. The central electron density is $8 \times 10^{19} \text{ m}^{-3}$ and the central electron temperature is of 2keV. The density and temperature are decaying exponentially in the scrape-off-layer region. Four waveguides of 6 cm in height located on the low field side of the torus couple to the plasma 600kW of microwave power at 4.6 GHz with a toroidal refractive index $n_{\text{tor}} (= ck_{\text{tor}}/\omega)$ of 2.3.

Figure 9 shows a logarithmic plot of the parallel electric field in the poloidal cross section of the Alcator C-Mod tokamak. In the full wave simulation, the waves propagate through the

waveguide structure as a TE_{10} mode. The seamless handling of the coupler and the plasma regions allows one to take into account the reflection from the plasma.

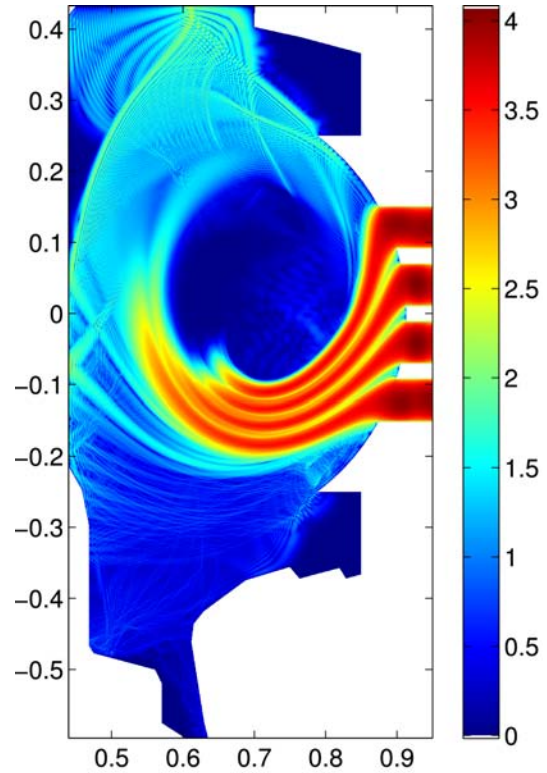

Illustration 9: Logarithmic plot of the parallel electric field $\log_{10}(|E_{\parallel}| + 1)$ resulting from the full wave simulation

The logarithmic plot clearly shows how the LH waves are not confined in the hot plasma region, but can propagate also throughout the scrape-off-layer region. Figure 10 shows the corresponding power deposition profile. Most power is deposited between a normalized radius of 0.2 and 0.5, which is consistent with the relatively low temperature of the plasma.

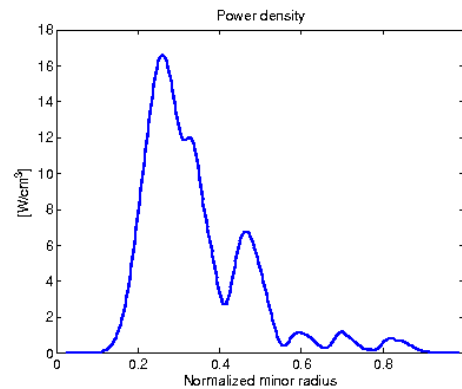

Illustration 10: Radial power deposition profile

5. Conclusions

A new method to simulate the propagation of lower hybrid (LH) waves in fusion plasma was developed. Our code consists of two parts which are coupled together, one which calculates the hot plasma absorption and the other which solves Maxwell's equations using a FEM approach.

The part of the code which involves the solution of Maxwell's equations was based on COMSOL, a commercially available FEM package which has been a key element at accelerating the development of our technique.

The unique result of our work is that we were able to find the solution to the non-local hot plasma absorption problem, while at the same time keeping the numerical efficiency of the FEM. Also, the FEM based approach allows the electromagnetic problem to be solved as a whole, from the antenna to the core of the plasma.

An extensive work of validation is under way and will be reported in future publications.

6. References

1. A. Boozer, Physics of magnetically confined plasmas, Reviews of Modern Physics, Vol 76, 2004
2. T. H. Stix, Waves in Plasmas, Springer-Verlag, 1992
3. P. T. Bonoli and E. Ott, Physics of Fluids, 1982
4. J. Wright, P. T. Bonoli, An assessment of full wave effects on the propagation and absorption of lower hybrid waves, Physics of Plasmas, 2009
5. IH Hutchinson, First results from Alcator-C-MOD, Physics of Plasmas, 1994
6. S. Shiraiwa, O. Meneghini, R. Parker, G. Wallace and J. Wilson, Plasma wave simulation based on versatile FEM solver on Alcator C-mod, 18th Radio Frequency Power in Plasmas, 2009
7. O. Meneghini, S. Shiraiwa, R. Parker, Full wave simulation of Lower Hybrid waves in Maxwellian plasma based on the finite element method, Physics of Plasmas, 2009
8. S. Shiraiwa, Plasma wave simulation based on a versatile FEM solver on Alcator C-Mod, invited talk at APS Division of Plasma Physics 2009
9. MUMPS: a MULTifrontal Massively Parallel sparse direct Solver, <http://mumps.enseeiht.fr>
10. National Energy Research Scientific Computing Center, www.nersc.gov
11. O. Meneghini, J. Hillairet, M. Goniche, R. Bilato, R. Parker, TOPLHA and ALOHA: comparison between Lower Hybrid wave coupling codes, APS 2008
12. J. Hillairet, D. Voyer, B. Frincu, O. Meneghini, A. Ekedahl, M. Goniche, Modeling of lower hybrid antennas using the ALOHA code and comparisons with Tore Supra experiments, Fusion Engineering and Design, 2009

9. Acknowledgments

Work supported by USDOE awards DE-FC02-99ER54512 and DE-AC02-76CH03073.