

COMSOL NEWS

THE MULTIPHYSICS
SIMULATION MAGAZINE



Powering E-Trucks with Long-Lasting, Reliable Batteries

Volvo Trucks is using a simulation app to design batteries that support long distance highway travel



Watchmakers lean on simulation to optimize the acoustics of a minute repeater.

PAGE 12

With Its Roots Firmly Planted, Simulation Branches Out

The earth's organisms have had four billion years or so to adapt and evolve, arguably making nature the best design of experiments conceivable and, thus, a fertile source of inspiration for engineers. As we share on page 4, one research team took inspiration from evolution for the "inverse design" process it used to optimize the topology of hydrogen fuel cell flow-field plates. Tellingly, the optimized designs resembled leaves, lungs, and blood vessels. The same article shares how a cleantech startup was inspired by the natural heat storage capacity of sand when designing its solar-powered urban heat distribution system. While nature provided the inspiration for these designs, it was high-fidelity multiphysics simulation — rooted in the physical interactions of the real world — that made their development possible.

Just as nature itself has continued to evolve, so too has simulation technology. Surrogate modeling, for example, is drastically reducing solution times for teams like the acoustics engineers at HEPIA, HES-So Geneva (page 12), who are fine-tuning luxury-watch minute repeaters with a surrogate-model-led process that's approximately seven times faster than a classical approach. Meanwhile, simulation apps that package advanced multiphysics models into intuitive, easy-to-use interfaces are putting the power of modeling into the hands of team members in the field, lab, C-suite, and factory. You'll find simulation app success stories on pages 6 and 16, where we share how Volvo uses a laser-welding app to accelerate e-truck battery design and researchers at DTU use simulation apps to predict electronics corrosion. As simulation technologies continue to evolve from the solid foundation of multiphysics modeling software, the potential of what can be built and optimized will only grow.

Joseph Carew
COMSOL, Inc.

INTERACT WITH THE COMSOL COMMUNITY

BLOG comsol.com/blogs

FORUM comsol.com/forum

LINKEDIN™ linkedin.com/company/comsol-inc

INSTAGRAM® instagram.com/comsol.multiphysics

We welcome your comments on *COMSOL News*. Contact us at info@comsol.com. To view these stories and their related resources (including references and models) online, visit comsol.com/stories.

© 2026 COMSOL. COMSOL, COMSOL Multiphysics, COMSOL Server, and COMSOL Compiler are either registered trademarks or trademarks of COMSOL AB. All other trademarks are the property of their respective owners, and COMSOL AB and its subsidiaries and products are not affiliated with, endorsed by, sponsored by, or supported by those trademark owners. For a list of such trademark owners, see www.comsol.com/trademarks.

LinkedIn is a trademark of LinkedIn Corporation and its affiliates in the United States and/or other countries. Instagram is a registered trademark of Instagram, LLC.

TABLE OF CONTENTS

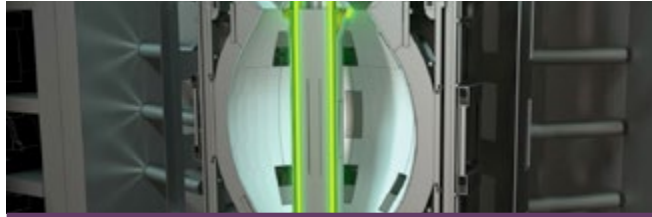

RESEARCH SPOTLIGHT

- 4 Taking Design Inspiration from Nature**
COMSOL, USA
- 16 Identifying the Root Cause of Electronics Failures with Simulation Apps**
Technical University of Denmark, Denmark
- 28 A STEP in the Right Direction: Modeling AC Losses in a Tokamak Design**
United Kingdom Atomic Energy Authority and Demcon Multiphysics, United Kingdom



DEMOCRATIZING SIMULATION

- 6 Express Delivery: Simulation App Speeds Up Electric Truck Battery Design**
Volvo Trucks and Resolvent, Denmark
- 22 High-Voltage Switch Innovation for Electric Power Systems**
Pinggao Group, China

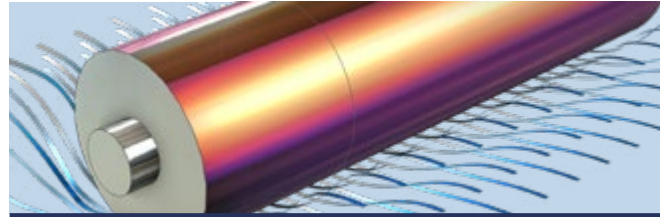

SIMULATION-BASED PRODUCT DEVELOPMENT

- 9 Voxelgrids Pioneers Accessible MRI Technology Through Virtual Analysis**
Voxelgrids Innovations, India
- 19 Improving Battery Design for eVTOL Aircraft with Simulation**
COMSOL, USA

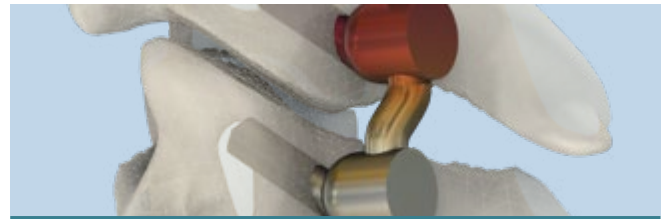

DESIGN OPTIMIZATION

- 12 Analyzing a Timeless Tradition Found in Ultra-Luxury Watches**
HEPIA, HES-SO, Switzerland
- 26 Medical Device Design with Multiphysics Simulation and AI Support**
COMSOL, USA

Taking Design Inspiration from Nature

by JOSEPH CAREW

The natural world is the ultimate experimental playground. In many cases, organisms have had millions of years to perfect how they operate within their environment. As a result, scientists and engineers across industries turn to this rich resource for device and system design inspiration. When such information is combined with modeling and simulation software, the design scenarios are endless. Here, we showcase some intriguing examples of engineers who drew inspiration from the natural world to overcome their challenges.



Microchannels and Generative Design

The first nature-inspired design example involves using hydrogen, the most common element in the universe, as a way to power vehicles. At the Toyota Research Institute of North America (TRINA), the development of hydrogen vehicles is a large focus.

The TRINA team developed a simulation-driven generative design method that was used in the design of flow field microchannel plates. These plates control how fluid reactants move through microreactors such as hydrogen–oxygen fuel cells.

The model created by the team generated, among other designs, a reaction-optimized microchannel design that may seem familiar to biologists: The microchannels distribute fluid reactants similarly to the distribution pattern found in leaves, lungs, and blood vessels.

Conventional thinking may have pointed the team at TRINA toward straight channels with no side branching, but the team found much more success with the reaction design that showed a similar pattern to those in naturally occurring systems.

Urban Rooftop Drainage System

Nature-inspired designs can be particularly important or notable in urban settings, and this was the case for the second design example. Copenhagen, as with most cities, needs to effectively remove or store excess rainwater in a nondisruptive way. The city also has to manage air quality, as areas that are highly populated with people but have little greenery can raise concern regarding livability and environmental effects. A professor at the University of Copenhagen worked with a team of engineers, architects, and citizen stakeholders to tackle the problems of handling excess water and promoting more biodiversity in an urban setting. Their solution? To develop a garden fence that doubles as a rooftop drainage system.

The resulting system is a willow-sheathed fence covered in vines and surrounded by other plant life, creating a garden-like atmosphere. Pipes collect rainwater runoff from nearby apartment buildings, transferring the water to the drainage system concealed within the fence. Once the water has reached the top of the screen structure, it flows along an open perforated gutter and is absorbed by blocks of fibrous "mineral wool", a rock-based material that then gradually releases the water into the air. Some water is released from the bottom of the structure, captured by a soil-filled chamber that irrigates the vegetation surrounding the fence. Overall, the project offers a green solution (literally) to an urban environmental problem.



Heating Buildings with Solar Energy Stored in Sand

While the first design example leaned on patterns found in different natural systems, the third design leans on the natural properties of a team's environment: The engineers at Polar Night Energy used COMSOL Multiphysics® to develop a heating system that could provide warmth during Finland's cold nights without relying on methods that harm the environment.

To find a solution, they turned to a component often associated with the beach: sand. The team's design can heat buildings with solar energy stored underneath the ground by leveraging the natural heat storage capacity of sand.

The process begins with the air inside of the system being heated to more than 600°C via electrically powered resistive heating elements. Then, the hot air is circulated through a pipe network inside of a sand-filled heat storage vessel. The hot air exits the vessel and goes into a heat exchanger, where it heats water that is circulated through the heating systems of buildings. The sand's heat storage capacity ensures that the circulating air is hot enough to keep the water (and buildings) warm.

A Natural Source of Inspiration

The natural world will continue to serve as powerful inspiration for those looking to develop all sorts of devices and processes. As we have seen here, finding ways to harness nature in urban settings and replicate natural behaviors can give us elegant solutions to complex problems. It is this potential that inspires design engineers and researchers across disciplines, and simulation helps make their visions a reality.

Volvo Trucks and Resolvent, Denmark

EXPRESS DELIVERY: SIMULATION APP SPEEDS UP ELECTRIC TRUCK BATTERY DESIGN

by BRIANNE COSTA

Using a laser-welding simulation app, Volvo Trucks has accelerated the design of long-lasting, high-performance batteries that can power its electric trucks. The app was developed with academic and industry partners, including the engineering consultancy company Resolvent.



These days, no one blinks an eye at 2-day, 1-day, and even same-day package deliveries. Despite the plethora of localized fulfillment and distribution centers that have cropped up to meet the demand, delivery trucks still need to make considerably long drives, often over highways. To reduce fuel and maintenance costs as well as carbon emissions, companies are investing in electric trucks for their delivery fleets. While turning to electric trucks is a promising solution, the battery packs incorporated into these automotive designs often fall short in the lifetime needed to make long-distance highway travel feasible.

To help overcome the issue of battery lifetime, a consortium of universities and industry partners incorporated multiscale simulation and a custom simulation app into the battery manufacturing process. The organizations involved in this

FIGURE 1 A Volvo® electric truck.

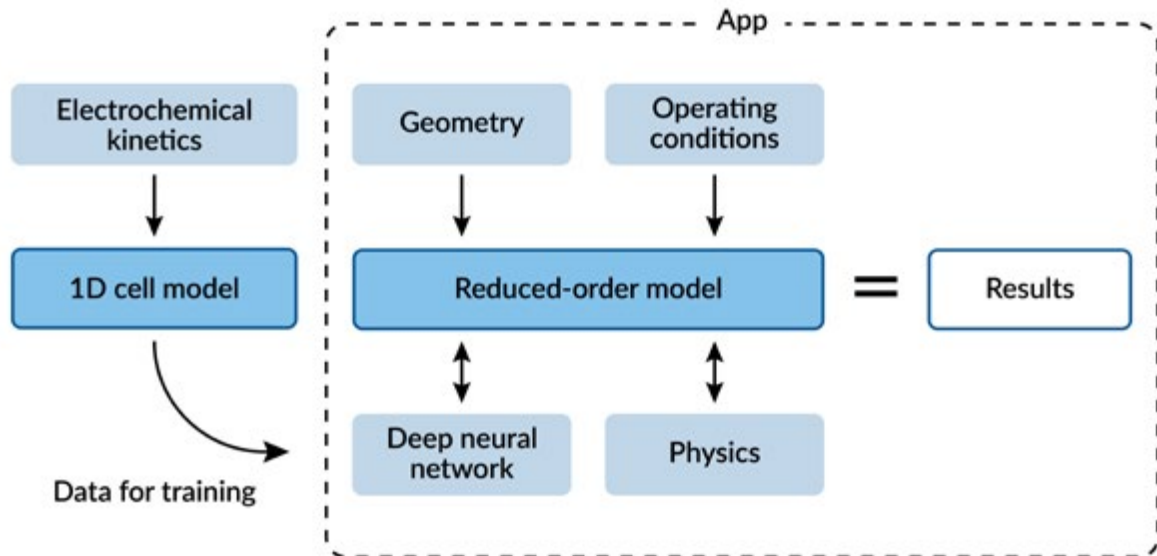

FIGURE 2 The Resolvent battery model.

project were Aurobay, Resolvent, the European Commission, the Technical University of Denmark (DTU), Vinnova (the Swedish Agency for Innovation Systems), Innovation Fund Denmark, and Volvo Group Trucks Operations.

The simulation app, built by Resolvent, a Denmark-based engineering consultancy that specializes in green energy, enables the R&D department at Volvo to easily test battery lifetime performance.

» LASERWHO?

The Multiscale Simulation of Laser Welding for Optimal Battery Pack Manufacturing project — referred to as "LaserBATMAN" — was initiated in May 2022 and wrapped up in May 2025 (Ref. 1). Although *BATMAN* here refers to *battery manufacturing* and not the famous masked superhero, the goals for the project also strove for greatness.

The LaserBATMAN project aimed to optimize two key performance metrics for battery packs: robustness and lifetime (Ref. 2). One element of the battery manufacturing process that affects both of these metrics is the laser welding used in component joining processes (for example, to connect battery cells in a pack via a busbar). If done correctly, it can positively impact battery life, but if done incorrectly, laser welding can increase the risk of battery degradation. Computational modeling can be used to analyze and predict the effects of welding

and joining processes at different stages of the manufacturing process.

Martin Refslund Nielsen, former chief commercial officer and partner at Resolvent, explained that for this type of multiphysics and multiscale problem, "COMSOL Multiphysics is just the right tool."

» R&D WORKFLOW FOR MULTISCALE MODEL AND APP

The Resolvent team used the COMSOL Multiphysics® software to study how laser welding affects the electrochemistry and degradation of battery cells. At least, that's how the project started.

"Ambitions grew," Nielsen said, explaining that the team ended up modeling the performance of the entire battery, from cell to pack level, and even "turned [the model] into a design tool in the end," in reference to the app.

First, the team built an electrochemical model of a battery cell by inputting the formulas for the relevant chemical reaction kinetics (Figure 2). The resulting 1D detailed electrochemical model of the cell was then fed input data, and the output data was used to train a deep neural network (DNN). With this surrogate model, the team was able to quickly gain insight into cell behavior.

After training the DNN of the battery model, the team built a custom simulation app to efficiently optimize busbar tabs in the configuration of a battery pack.

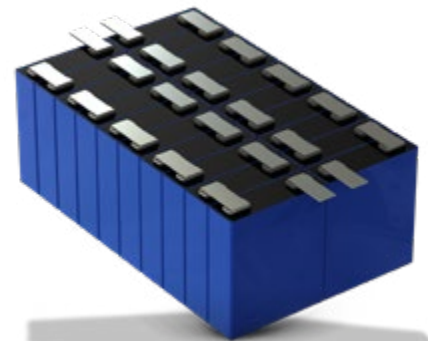

FIGURE 3 The battery pack model developed by Resolvent.

» A "TOOL WITHIN A TOOL" FOR BUSBAR WELD DESIGN

The different features of the simulation app, as described by Nielsen, include its options to input dimensions for the pack geometry (Figure 3), the number of cells, and operating conditions such as ambient temperature and charge–discharge current profiles. The app also makes it possible to apply a simple charging current and load customized cycles. Users are then able to see how the battery performs with each set of specific inputs.

Another important aspect of Resolvent's app is the *Busbar Weld Design Tool* button, which Nielsen described as "a tool within a tool". This button can be used to efficiently calculate busbar weld performance after a number of cycles.

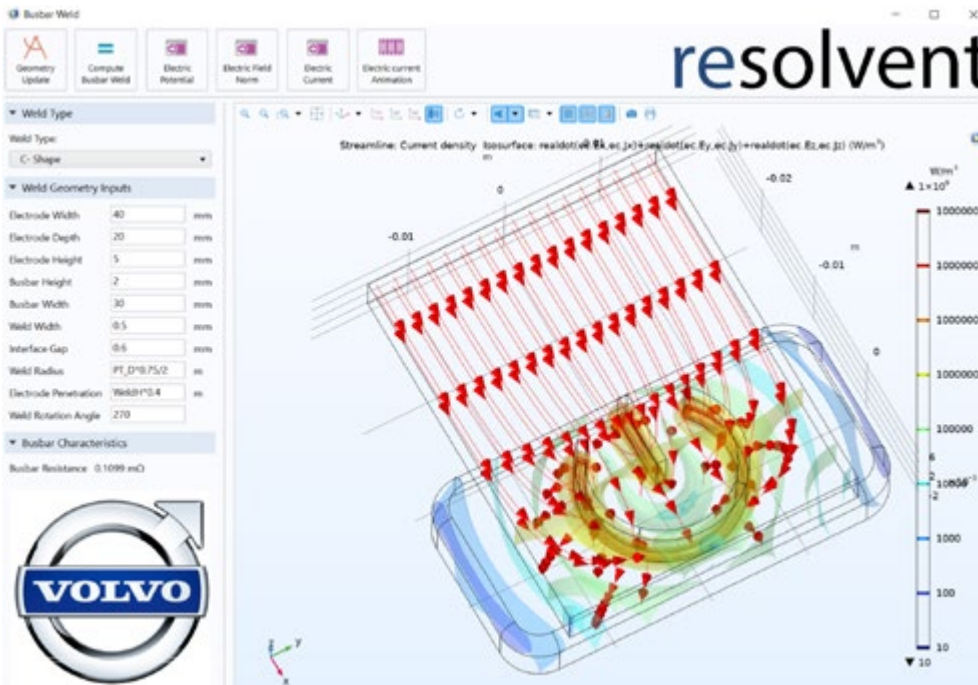

FIGURE 4 Resolvent’s simulation app, showing how certain parameters can be customized. The model shows how the busbar weld is affected by a cooling airflow.

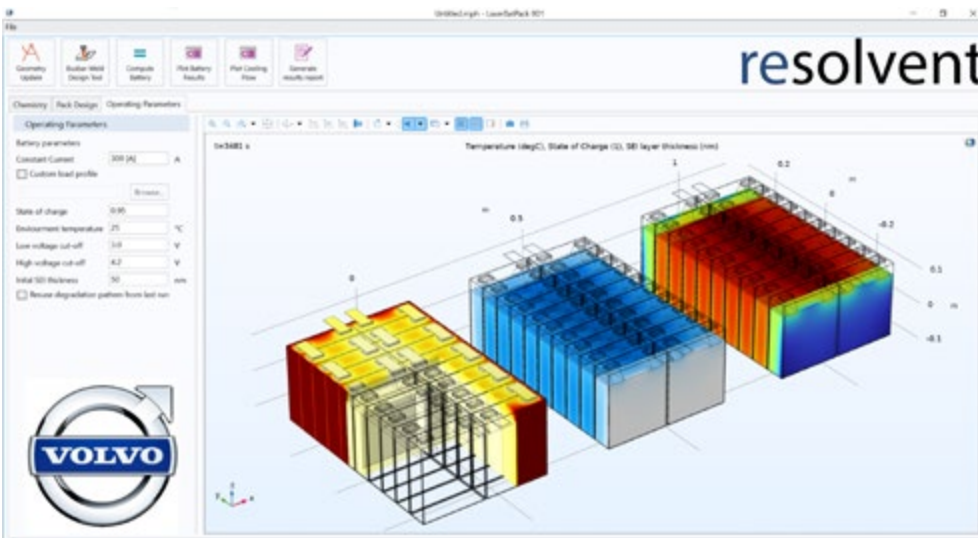

FIGURE 5 Temperature in the given state (left), state of charge (middle), and SEI layer thickness (right) in the battery pack.

After clicking the button, a window opens with options for setting different parameters, including the shape of the weld, busbar thickness, and penetration depth of the laser (Figure 4).

"[This button] is interesting from a robust design perspective," said Nielsen. Users can apply a variant to the input

parameters to see what happens in production if the weld does not reach far enough into the busbar.

"We certainly get deep technical insight here, and we can dimension the design in the sweet spot. Deep technical insight is also key to optimizing product performance," Nielsen said.

For example, if the results suggest better cooling, the team could potentially reduce the design by two battery cells and retain the same performance, easily quantifying the tradeoff between cooling and setup.

» PREDICTING PACK PERFORMANCE

The app’s user interface also includes a *Compute Battery* button, which can be used to see the temperature of the weld in a given state, the state of charge, and the solid–electrolyte interface (SEI) layer thickness (Figure 5). The results can help the engineering team further determine if there is room for optimization in the design. For instance, a user can apply a cooling flow in the app and see if turbulence or standing air occurs.

As explained by Nielsen, simulation apps offer more consistent analysis and reporting, and the intuitiveness of custom apps makes it easier to share knowledge. "We are in a much better place to optimize performance and increase robustness," said Nielsen.

The custom simulation app developed by the LaserBATMAN consortium can be used to help produce more robust battery designs with ranges that can support highway travel over longer distances with fewer failures — all while promoting the use of green energy. A heroic project indeed. ☺

REFERENCES

1. "LaserBATMAN," University of Skovde, accessed 08/21/2025, <https://www.his.se/en/research/virtual-engineering/virtual-manufacturing-processes/LaserBatman/>.
2. R. Nielsen, "Keynote: Optimizing Lifetime and Robustness of Electric Truck Batteries with Simulation Apps," COMSOL Conference 2024 Florence, October 2024.

Voxelgrids Innovations, India

VOXELGRIDS PIONEERS ACCESSIBLE MRI TECHNOLOGY THROUGH VIRTUAL ANALYSIS

Voxelgrids Innovations developed India's first MRI scanner that was fully produced domestically. Moreover, the machine was specifically designed to be more affordable for patients. To engineer this design, the company used multiphysics simulation.

by DHANANJAY MISHRA

In the race to make advanced medical imaging more accessible, Voxelgrids Innovations faced a big challenge: the weeks-long cooldown process for traditional MRI magnets. Using the COMSOL Multiphysics® software and its add-on Heat Transfer Module, the team compressed months of trial and error into days of virtual experimentation, reducing product development time by 40% while also eliminating the need for costly helium in its MRI machine. Ultimately, the team's work resulted in India's first indigenous commercial 1.5 Tesla (T) MRI scanner.

» CHALLENGES OF MRI SYSTEMS & VOXELGRIDS' SOLUTION

MRI procedures have saved countless lives, giving doctors a window into the human body unlike any other technology for decades. However, MRI tests remain out of reach for many, owing primarily to the high cost of such a procedure.

A major driver of that cost is the upkeep of the enormous superconducting magnets that make the technology possible. To work, these magnets need to be bathed in thousands of liters of liquid helium, which chills the magnets to extremely cold temperatures. This helium is expensive and often hard to obtain. Additionally, the chilling process is slow, taking up to three weeks before the machine can be reused.

Founded in 2017 by Dr. Arjun Arunachalam, Voxelgrids started with an ambitious goal: to make low-cost MRI procedures available to everyone. The team decided to build a powerful, compact 1.5 T scanner that relies on a conduction-based cooling system rather than liquid helium. At the core of this innovative cooling system is the cold head — a mechanically coupled cryocooler that extracts heat directly from the magnet to keep it at the superconducting state of 4.2 K. While helium-based MRI machines also

incorporate a cold head, Voxelgrids' cold head is specifically designed for conduction cooling, extracting heat away through conduction, and eliminating the need for liquid helium.

However, the team's idea came with several challenges. Firstly, not all cold heads perform the same way. Their performance is dictated by complex, interdependent two-stage cooling curves, where the cooling capacity at each stage varies nonlinearly with temperature. Additionally, the contact resistance between metal surfaces, the pressure at interfaces, and heat transfer between components could dramatically alter the system's behavior. These factors are very difficult to measure and account for. Moreover, with every new design idea, the team faced a two-week cooldown process to see if the idea worked.

"We would choose a cold head, bolt it on, and start the cooldown," said Dr. Ashok KB, a senior simulation engineer at Voxelgrids. "Then came the hard part:

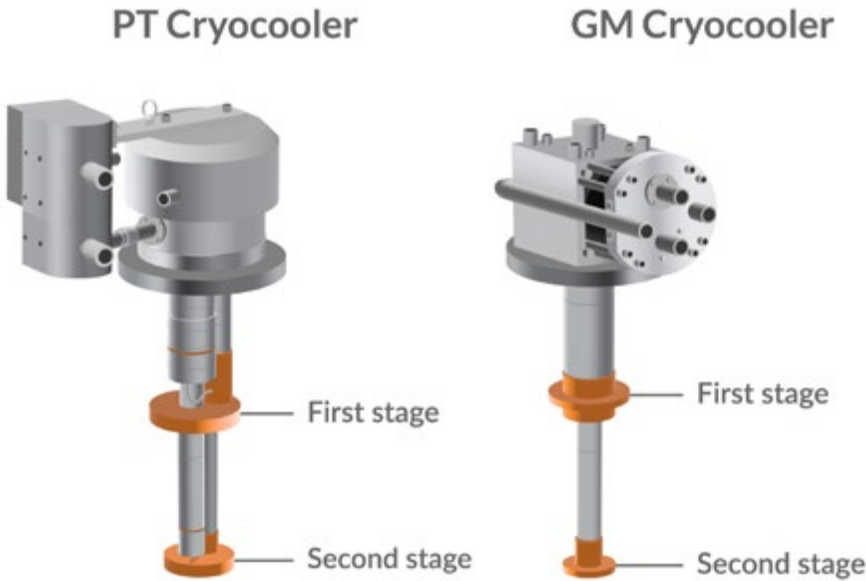

FIGURE 1 Examples of a Gifford–McMahon (GM) cryocooler and pulse tube (PT) cryocooler, showing where the first and second stages of cooling occur.

waiting. For almost a month, we would watch and hope, only to find out the design had a weak spot or a heat flow issue. Back to square one."

For a startup aiming to innovate rapidly, this timeline was an operational and financial impossibility. The team needed an accurate and reliable way to test its ideas without spending weeks waiting for an answer. To choose a cold head design with more confidence and reduce prolonged prototyping, the team used multiphysics simulation.

» SIMULATING THE COOLDOWN PROCESS

In an MRI system, a two-stage cooling mechanism is employed to maintain the superconducting magnet at the cryogenic temperatures required for operation. For the first stage, the cold head acts as a thermal barrier, operating at an intermediate temperature range of approximately 40 to 50 K to cool the surrounding radiation shield. This process effectively blocks external heat loads before they can reach the magnet assembly and creates an

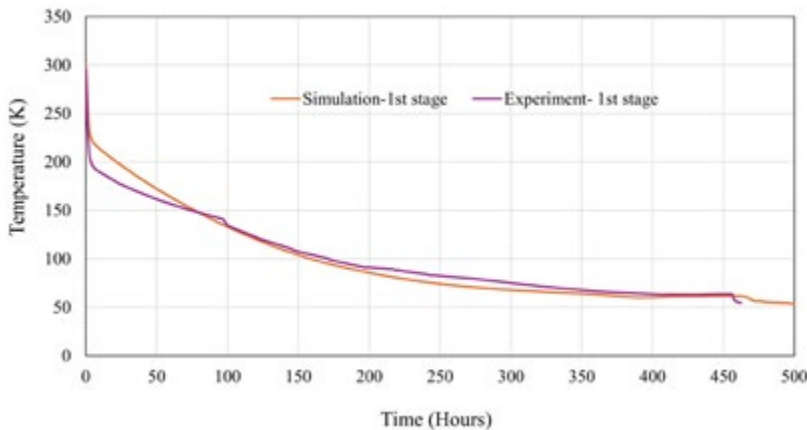

FIGURE 2 The comparison between the simulation and experimental cooldown results for the first stage of cooling.

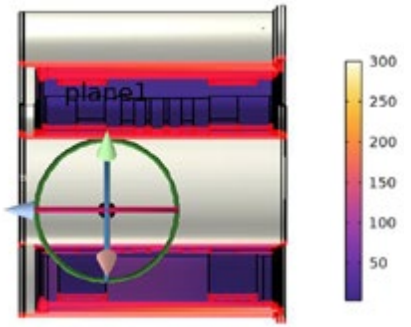

FIGURE 3 Temperature distribution within the magnet assembly during cooldown.

environment for the second stage to start. The second stage achieves the ultimate base temperature of around 4 K, which is necessary to sustain the superconducting state of the magnet coils.

The team members at Voxelgrids built a detailed virtual model of their conduction-cooled magnet system. The first task was accurately modeling the cold head, which was useful for dynamically calculating how much heat could be removed at every temperature point during the cooldown. Figure 2 shows how the virtual model of the cold head closely agrees with the simulation results of the first stage of the cooldown process.

The simulation-driven approach gave the team the freedom to explore a wide range of design possibilities. With multiple cold head options available, where each had its own unique two-stage performance characteristics, the team was able to test different permutations and combinations virtually. By simulating various scenarios, the engineers compared cooldown behavior and temperature stability, eventually zeroing in on the design that best met their requirements. The simulation also enabled them to investigate critical failure modes. They simulated what would happen if the cold head did not operate properly and the temperatures of the first and second stages, which are vastly different, were to accidentally overlap. These simulation results confirmed that the final design would maintain proper thermal isolation under real-world operating conditions, giving the team confidence before moving to physical prototyping.

Additionally, while the engineers initially started with a basic cold head design, they then added more physical phenomena to enhance the model. Thermal contact resistance at mechanical joints, which can create significant insulating barriers, was defined based on surface finishes and clamping pressures. Radiative heat exchange between surfaces inside the vacuum chamber was also added. This multiphysics approach enabled the team to create a model that closely resembles the real world.

» VISUALIZING TEMPERATURE DISTRIBUTION

The team found that one of the most impressive outcomes of the model was being able to visualize the thermal landscape of the magnet during cooldown. The simulation generated detailed temperature contours and gradient plots of the magnetic assembly, as shown in Figure 3.

These results were essential for observing how the heat propagated from the cold head through the complex magnet structure. Areas were identified where heat was trapped due to poor thermal pathways or where excessive thermal mass was slowing the process. These results led the team to exactly pinpoint the areas that were conducting too much heat, offering critical insight for mechanical design iterations.

» VALIDATING THE SIMULATION RESULTS

The ultimate test of any model is its agreement with the real world. After optimizing the design in the virtual space, the team built a prototype and initiated a cooldown. The team monitored the temperature drop at key locations, comparing the experimental results against the simulation's prediction curve.

The results matched almost perfectly, with the simulation predicting a cooldown time to operating temperature of approximately 20 days, whereas the physical experiment took about 21 days (Figure 4). The slight discrepancy was attributed to the electrical components that had been omitted from the initial model for simplicity. This close correlation between the experimental results and virtual model confirmed that multiphysics simulation could accurately predict the performance.

» FROM MONTHS TO HOURS: ACCELERATING THE PATH TO IMPACT

The impact that the use of simulation had on the development process was measurable. The months-long cycle of designing, building, and testing was accelerated, leading to parallel exploration of multiple designs. A single virtual cooldown analysis could be completed in less than eight hours, enabling the team to evaluate multiple cold head configurations, interface materials, and mechanical layouts in the time it would have originally taken to perform one physical test. The software also enabled the team to analyze failure modes and edge-case scenarios safely

and at a low cost, as well as simulate the effects of a degraded cold head or improper assembly in order to understand the system's robustness.

The team's accelerated innovation had a significant impact on the medtech industry: Voxelgrids developed India's first locally made commercial 1.5 T MRI scanner (Figure 5), deployed at Chandrapur Cancer Hospital in Nagpur, India. The machine is compact, lightweight, and was designed to be deployed and operated under the most challenging installation conditions while still generating outstanding images for clinical diagnosis. With this machine, the team achieved a major goal of helping to make MRI treatments more accessible. ©

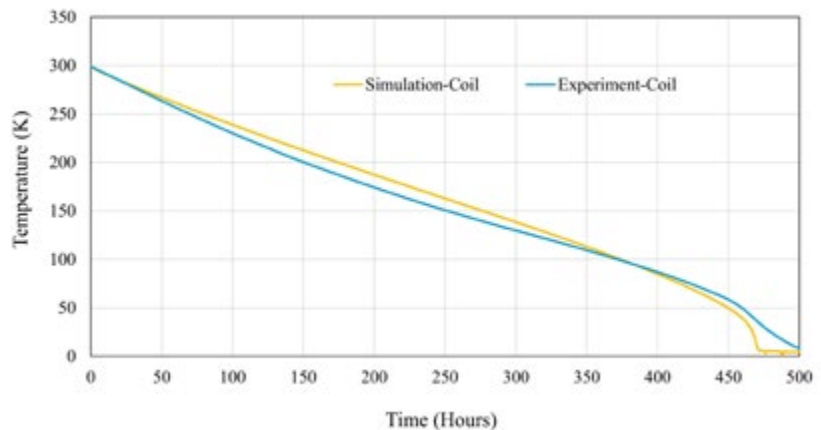

FIGURE 4 Close agreement between simulated and experimental cooldown curves validated the accuracy of the multiphysics model.



FIGURE 5 Voxelgrids' innovative MRI system, deployed at Chandrapur Cancer Hospital, Nagpur, India.

HEPIA, HES-SO, Switzerland

ANALYZING A TIMELESS TRADITION FOUND IN ULTRA-LUXURY WATCHES

Engineers at HEPIA, HES-SO Geneva use the COMSOL Multiphysics® software to model and simulate the acoustics of a minute repeater, a rare and sophisticated mechanism in watchmaking. With the software, the engineering team use the boundary element method to carry out optimization calculations based on surrogate models.

by MACKENZIE MCCARTY

Some luxury watches feature a minute repeater — a complex mechanical function in which tiny hammers strike tiny gongs to produce distinct musical chimes signifying the hours, quarter-hours, and minutes of the day. Activated on demand by a button or lever, minute repeaters were originally designed to tell time in the dark. Today, they are considered pieces of art, worn to represent status, craftsmanship, and a link to the past.

Building these intricate mechanisms requires significant skill and extreme precision to achieve just the right chime tones. Hundreds of small components are involved, highlighting

the importance of an optimized design. Engineers at the Institute of Technology (inTECH) at the School of Engineering, Architecture and Landscape (HEPIA) in Geneva, part of the HES-SO University of Applied Sciences and Arts Western Switzerland, used the COMSOL Multiphysics®

software and a simplified 2D model to simulate the acoustic performance of a minute repeater.

We spoke with Roland Rozsnyo, a researcher and lecturer on mathematics at HEPIA, about his use of COMSOL Multiphysics in the horology industry and



FIGURE 1 An Audemars Piguet Royal Oak Minute Repeater Supersonnerie watch. On the back of the watch, one can see the openings through which the sound is emitted. Images courtesy of high-end watch manufacturer Audemars Piguet.

specifically with the minute repeater. He discussed how the software can be used to optimize the hammer's impact location on the watch's gong, or timbre, to enhance both the radiated acoustic intensity and the spectral content of the sound while also addressing the computational efficiency of the simulations performed. The acoustic signature is a key quality attribute of these luxury watches, and optimizing its sound production process is critical for user satisfaction and product differentiation. Numerical modeling was used extensively due to the complexity of acoustic propagation in small mechanical structures and the need for high-fidelity simulations.

Q What is the minute repeater, and what role does it play in modern watchmaking?

RR: The minute repeater remains one of the most prestigious and rare features in watchmaking. It is mainly found in high-end and ultra-luxury watches produced in very limited quantities (Figure 1). Although it is no longer a practical necessity in modern life, it retains a very strong symbolic value, representing extreme mechanical mastery and centuries of horological tradition. Customers are still attracted to minute repeaters for their emotional, artistic, and patrimonial value. The sound itself, its musicality, and the unique acoustic signature of each watch make the minute repeater a true object of art rather than a simple timekeeping function.

The minute repeater is programmed to chime the time on command. Watchmakers wish to have a very nice sound, and they

wish to understand what the key parameters are to have this nice sound for a given frequency. The principle of a minute repeater watch is that you have a gong, and this gong is struck by a hammer, creating a vibration that propagates to the glass or to a vibrating membrane, and this radiates the sound into the air.

Q How do you use COMSOL Multiphysics® to optimize the acoustic performance of the minute repeater?

RR: Initially, a theoretical comparison between the finite element method (FEM) and the boundary element method (BEM) is conducted in COMSOL Multiphysics®. FEM requires meshing both the solid and surrounding air volume, resulting in a high computational burden. In comparison, BEM only requires meshing the boundaries, significantly reducing memory and time requirements in acoustics, especially in unbounded domains. The study revealed that BEM provides similar acoustic results to FEM but substantially reduced computation time and resources (Figure 2).

The COMSOL Multiphysics simulation used a simplified 2D model of the minute repeater mechanism in order to optimize its acoustic performance (Figure 3). The hammer–gong interaction is modeled with multibody dynamics, simulating contact, spring, and damping effects to generate structural vibrations.

BEM is used to compute the radiated sound field in the frequency domain using the acceleration at the structural boundaries. A surrogate model based

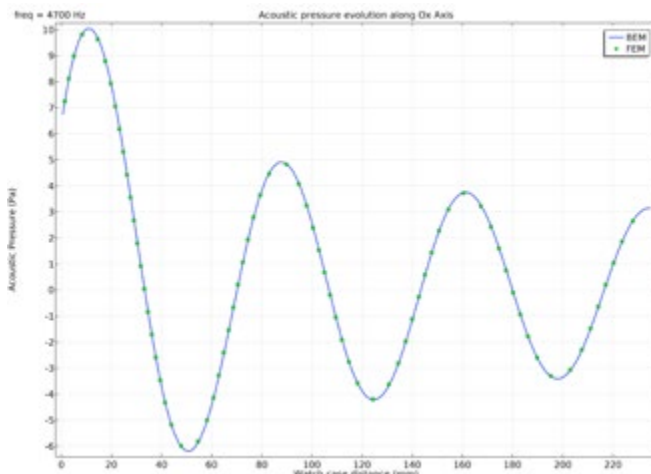

FIGURE 2 Comparison between 2D FEM and BEM.

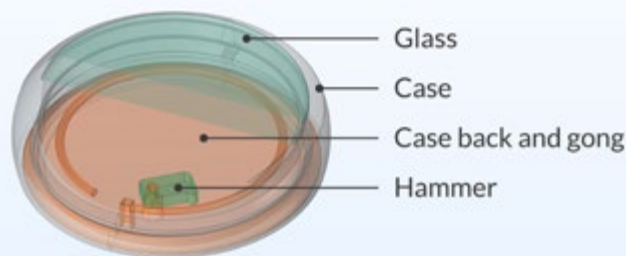
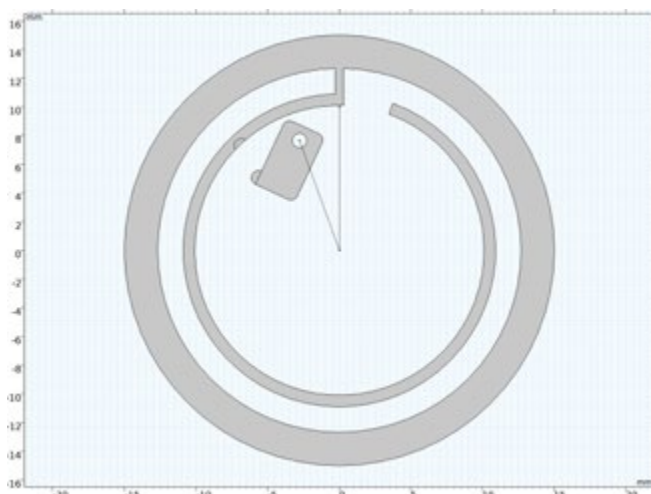

FIGURE 3 Simplified 2D geometry of a minute repeater mechanism (top) and the simplified design in 3D geometry (bottom).

on deep neural networks (DNNs) trained on BEM data was used to approximate the acoustic response with reduced computational cost. The efficient global optimization (EGO) algorithm was used to enable fast optimization iterations.

The simulations determine which hammer impact positions optimize acoustic intensity and tonal quality while minimizing a defined cost function. This also demonstrates a significant reduction in computation time while providing a framework for advanced horological acoustic design.

To properly capture high audible frequencies in a one-meter air volume around the watch using FEM, extremely fine meshes are required (typically at least five elements per wavelength), which leads to very large models in terms of memory and computation time. With BEM, only the watch geometry is meshed, while the air domain is handled implicitly through the integral formulation. Although the system matrices are dense, they remain much smaller than FEM volumetric matrices. This results in significant memory savings and faster overall computation, especially in 3D and at high frequencies.

The BEM results allow us to analyze acoustic radiation, sound intensity, directivity, and the influence of case geometry with a very good balance between physical accuracy and numerical efficiency.

Q Do you combine modeling with experimental testing?

RR: Yes, modeling is systematically combined with experimental testing. At HEPIA, our applied acoustics group has full instrumentation to characterize watch acoustics, including an anechoic chamber (Figure 4) and dedicated acoustic and vibratory measurement systems. We routinely compare simulation results with experimental

measurements. This allows us not only to validate the numerical models but also to improve them by better identifying certain physical parameters that are difficult to estimate purely theoretically. This hybrid approach ensures that our simulations remain reliable and industrially relevant.

Q Do you think there's room for modeling and simulation to expand and evolve in the watchmaking industry?

RR: Yes, of course. I would say the watch industry is only at the beginning of using simulation. They've used a lot of mechanical simulations, but now they are using more and more multiphysics simulations. With features like optimization and now surrogate modeling, this is very new. We've shown that the use of surrogate

modeling combined with multiphysics simulation led to an optimization process that was approximately seven times faster than a classical approach based solely on direct numerical simulations.

More generally, this result illustrates the substantial computational gains that can be achieved with this methodology. While the exact acceleration factor depends on the problem, model complexity, and parameter space, surrogate-based approaches consistently provide significant reductions in computation time, making large parametric studies and optimization workflows feasible within industrial time constraints while preserving good physical accuracy. We have many parameters to study, and surrogate modeling really has reduced the computational costs in terms of time. We try to find all the possibilities to reduce the time, and COMSOL Multiphysics now offers the tools to do that.

Q What other aspects of COMSOL Multiphysics® do you use in horology?

RR: We use computational fluid dynamics to study lubrication and oil propagation, as well as the aerodynamic friction of a balance spring. We also have magnetic simulation to study the parts of the watch that are made of steel and the magnetic perturbation. We also use something called a drop test to test if the watch is waterproof. This test sets a watch into 40°C water under pressure and then removes the watch and puts a small drop of 5°C water on the glass. This causes a thermal shock, which makes steam appear on the glass. If the steam disappears after one minute, it means the watch is waterproof. If not, it's not waterproof. However, in new watches, they use specific coatings, which means thermal conductivity and glass



FIGURE 4 The anechoic chamber in the Applied Acoustics Laboratory at HEPIA.

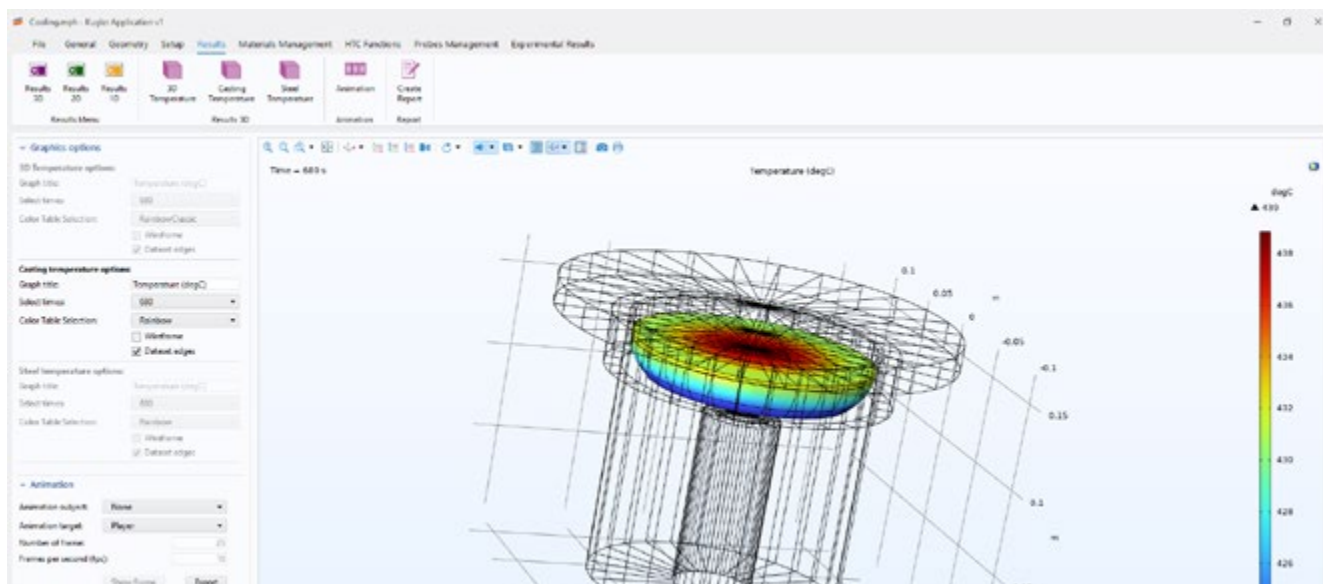

FIGURE 5 The user interface of Kugler Bimetal's simulation app, developed by the HEPIA team, and an example of computed results based on the underlying model. Image courtesy of Kugler Bimetal.

thickness are not always the same, so the standard test no longer gives the right results. They wish to use simulation to understand how to do that, so we modeled it.

It's a multiphysics simulation with three coupled physics: a laminar flow coupled to heat transfer with phase change and moisture transport. This is all at a very small scale too, which adds to the challenges of any experimental testing. There are sensors that are able to check the temperature behavior of the watch while cooling in the air. We check that the simulation is correct and was validated.

Q How do you use simulation apps in your work?

RR: We developed simulation apps in projects for companies we collaborate with. The most recent collaboration was with Kugler Bimetal, a metallurgical company that is making bimetallic parts. For this process, we have a part coming from an oven at 1100°C. It should be cooled with pulsed air, and the

cooling process should be completely controlled because if the cooling is too fast or too slow, it will not give the good material properties in the final part.

People who are working on that process in the factory are not specialized in simulation. So, as part of a three-year project, we developed an app that is able to calculate the cooling very simply (Figure 5). It is designed for industrial operators. Our idea is to spread simulation to people who are not specialists. The operators can just check the results and check that what is happening is correct and change parameters quickly. It allows them to quickly explore the influence of manufacturing parameters such as geometry, materials, and thermal conditions on the mechanical and thermal behavior of bimetallic parts. They can understand, "If I set this parameter, it is better." They can do it directly in the factory. We set the key parameters, such as the oven temperature, which can be modified in the app as an

"We've shown that the use of surrogate modeling combined with multiphysics simulation led to an optimization process that was approximately seven times faster than a classical approach based solely on direct numerical simulations."

— ROLAND ROZSNYO, RESEARCHER AND LECTURER AT HEPIA

initial condition, and it will give a different cooling. People can change that very easily. It is not possible to have a computer in the factory, so they use tablets or mobile phones.

The results show a significant reduction in physical trials, better understanding of the process, and improved reproducibility of the manufactured parts. The app acts as a true decision-support tool integrated into the production workflow. ©

ACKNOWLEDGEMENTS

Roland Rozsnyo would like to gratefully acknowledge the following people for their assistance in the research described in this Q&A, including Romain Boulandet, an associate professor at HEPIA, HES-SO Geneva, specialized in numerical and experimental acoustics; Marc Chambordon, a research assistant at HEPIA, HES-SO Geneva (MSc in microtechnology); Víctor Sánchez Mejía, a research assistant at HEPIA, HES-SO Geneva (MSc in mechanical engineering), and Gaétan Simonnot, a mechanical engineer and research assistant at HEPIA, HES-SO Geneva. In addition, Rozsnyo would also like to acknowledge Alexandre Masserey, a scientific collaborator at HEPIA (PhD in applied mathematics), for developing the simulation app for Kugler Bimetal.

Technical University of Denmark, Denmark

IDENTIFYING THE ROOT CAUSE OF ELECTRONICS FAILURES WITH SIMULATION APPS

Researchers at the Technical University of Denmark (DTU) are using simulation apps to predict corrosion and design electronics proactively to mitigate or withstand its effects.

by JOSEPH CAREW

In pursuit of improved range, greater reliability, and faster charging, electric vehicles are driving the demand for high-voltage electronics. Other applications driving this demand include wind farms, data centers, and server farms, to name a few. As the interest for high-voltage electronics increases, the risks associated with their sudden failure must be considered. Much of what causes high-voltage equipment to malfunction can be linked to the conditions of the climate in which it operates. Specifically, condensation on electronic surfaces caused by humidity can lead to corrosion, which can result in stray leak current and dendrite shorting during Electrochemical Migration (ECM). Predicting, mitigating, and helping proactively design to account for corrosion is the focus of the Centre for Electronic Corrosion (CELCORR) research group at the

Technical University of Denmark (DTU). The group's researchers are working with industry partners to develop models and simulation apps that will help in building robust electronics designs. Their goal is to develop knowledge that can be used for manufacturing electronics to withstand humid operating conditions.

» ELECTRONIC FAILURE: "IT'S NOT THE HEAT; IT'S THE HUMIDITY"

Automotive electrification and renewable energy systems rely on electronics at all stages of the energy chain. When these electronics, such as the example PCB in Figure 1, are exposed to the effects of moisture, they can become potential failure points. "Anywhere you are producing, converting, transporting, and using energy, you need these high-power

electronic systems that get affected by the humidity," explained Dr. Rajan Ambat, DTU professor and manager of CELCORR. Ambient moisture can seep into the devices and machines that require these electronics and cause unexpected functional issues through corrosion. When these electronics are involved in particularly high-voltage applications (such as wind farms, data centers, electric vehicles, and server farms), failure due to humidity exposure can even lead to fire.

"There might be a situation where somebody installs a solar panel near the seashore or in an area with high humidity, and within a short period of time, a conducive condition forms inside the electronics that results in a failure," Ambat said. "This is why we need to understand exactly how the conducive condition of condensation is created,

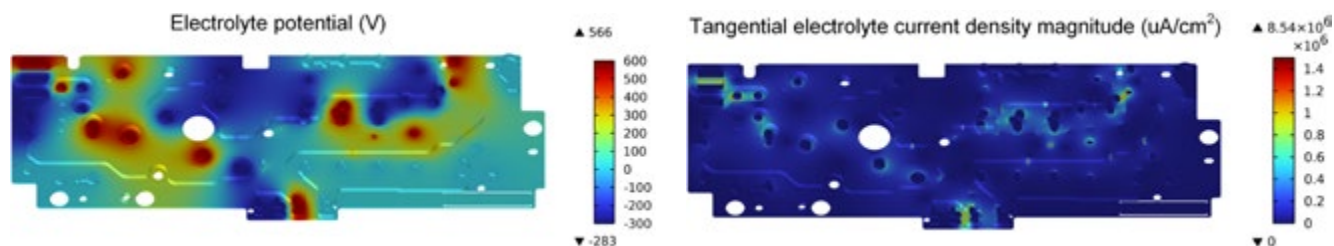

FIGURE 1 The electrolyte potential and current density distributions on a PCB surface (with pinholes).

when the condition is created, and how the system is failing."

Identifying corrosion as the underlying cause of some electronic failures is still a challenge. "Fifty percent of failures in electronics are currently branded with an unidentified root cause," Ambat explained. "When engineers open up the system, they do not realize that the failure was due to corrosion, because moisture disappears without leaving any sign of corrosion unless there is ECM dendrite formation." This lack of awareness was a strong motivator for CELCORR, which turned to multiphysics simulation as a supplementary tool to help its partner organizations to better predict humidity-related issues at the design stage.

» MODELING MOISTURE AND MEASURING PARAMETER CHANGES IN PCBs

CELCORR believes the best way to identify and avoid electronic failures is to build more effective designs that better prevent corrosion from developing or can withstand a higher humidity load. Its research team applies its expertise in modeling to generate simulation apps that will help partner industries to evaluate safe designs for humidity robustness.

"We are at the intersection of materials science and the electronics industry. We work as a bridge between materials and electronics disciplines, using both kinds of language," Dr. Anish Rao Lakkaraju, a postdoctoral researcher at CELCORR, explained.

To understand potential design issues, Ambat emphasized the importance of virtually breaking down systems to identify where problems may arise. "We need simulation software to analyze potential uses of designs and whether new designs are good or bad," Ambat said.

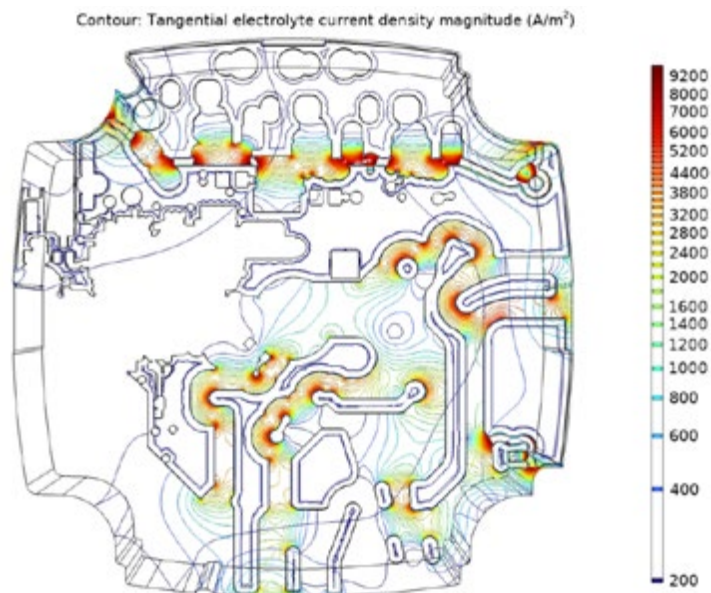

FIGURE 2 A 10-µm water film condensation effect on an example PCB.

Using the COMSOL Multiphysics® software for investigation, the CELCORR research team together with other research partners (Aalborg University) built an example model with a simple PCB geometry that matched both its test circuit boards as well as the design of a device used by one of its partner companies. The team then added a water film layer on top to act as the relative humidity. From there, the team could introduce variation. "We change the layout, geometry, distance between electrodes, thickness of the water film, and conductivity of the water film depending on the conditions," Ambat said.

Ambat and his team generate data on the effect of these variations and can identify which has the greatest impact on the device's performance and whether any alterations can improve the device's anticorrosion robustness. "We assume there is condensation forming on the electronic surfaces (Figure 2) and compute the electrochemical leak

current for different design elements," Ambat said. "The value of the computed electrochemical current between the parts will give us an indication of whether the PCB will be affected or not."

Altering the design elements and solving the model equations again and again allows the team to better understand what makes a design effective. "Now, we are at the current form of the model, and we are quite happy with where the physics are at this point," Lakkaraju said. This modeling, however, was just the first

"Fifty percent of failures in electronics are currently branded with an unidentified root cause."

— DR. RAJAN AMBAT, DTU PROFESSOR AND MANAGER OF CELCORR

part of CELCORR's overarching goal of illuminating the destructive potential of corrosion in electronics and the best ways to avoid it.

» USING SIMULATION APPS TO TEST REAL-WORLD DESIGNS

To open up and ease access to these models, CELCORR used the Application Builder in COMSOL Multiphysics® to create simulation applications for the members of the industrial consortium. Built with a simple 3D circuit board geometry with two oppositely biased electrodes and a water layer to replicate corrosion-causing moisture, the apps provide a pared-back, straightforward interface where users can vary model inputs. "We focused on fundamental

aspects," Lakkaraju said. "We boiled down our partners' overarching concerns to create two apps with very simple geometries and the simplistic stuff that can be varied over multiple parameters."

The simple simulation apps shown in Figures 3 and 4 are designed to show companies how the distance between the electrodes and the thickness of the moisture layer affect the leak current through the water film depending on different parameters. By analyzing multiple design elements and parameters, users can determine the relative benefits of certain design elements on the humidity robustness. "The apps we have built have really helped because they give the electronics engineers a plug-and-play sort of approach," Lakkaraju explained.

"By using this app [Figure 3], companies have unlimited freedom to work with these sorts of variables," Lakkaraju added. "This would be quite difficult to recreate in real life with physical design and testing, and the companies we work with are quite happy with the level of accuracy the app can provide."

» LOOKING FORWARD: COMPLEX, HIGH-VOLTAGE MODELING

Alongside its collaboration with the industry consortium, CELCORR is also working toward improving the world's general understanding of corrosion's impact on electronics. To do this, Ambat and his team are undertaking multiple projects, including actively adding greater complexity to their models. In a tertiary current distribution model they are building, the team is drilling down into each of the basic inputs used in a secondary current distribution model, zooming in to examine the effects of the set of even more detailed inputs each basic input comprises.

"The next point is to study what each of these detailed inputs does," Lakkaraju said. In particular, the team is examining mass transport properties and the chemical reactions' rate constants.

In addition to these ongoing studies, CELCORR is expanding the scope of its research to investigate corrosion in high-power, high-voltage systems. Thanks to a 2024 grant from the Grundfos Foundation, CELCORR was able to establish the Centre for Climate Robust Electronics Design (CRED). The center's lab facilities and expertise are being developed to address the humidity-robustness requirements of today's high-voltage and high-power electronic equipment. "Using CELCORR's uniquely deep understanding of materials and corrosion, we are equipped to find the root cause and provide knowledge for environmentally robust designs," said Ambat.

For all of its investigation, CELCORR continues to rely on the agility of the COMSOL Multiphysics® software. As Lakkaraju explained, "It is really quite nice how a model can be adapted to a variety of combinations of materials, geometries, and parameters and how the software allows you to keep building on from there." ☺

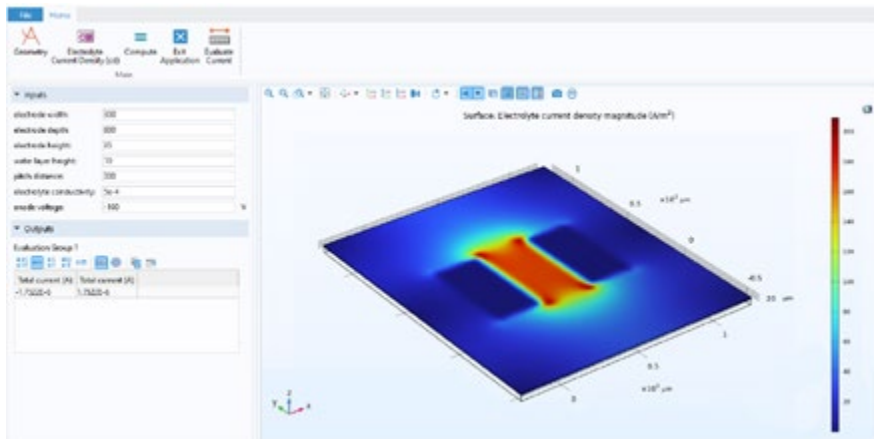

FIGURE 3 The UI of CELCORR's standalone app showing the inputs that users can alter.

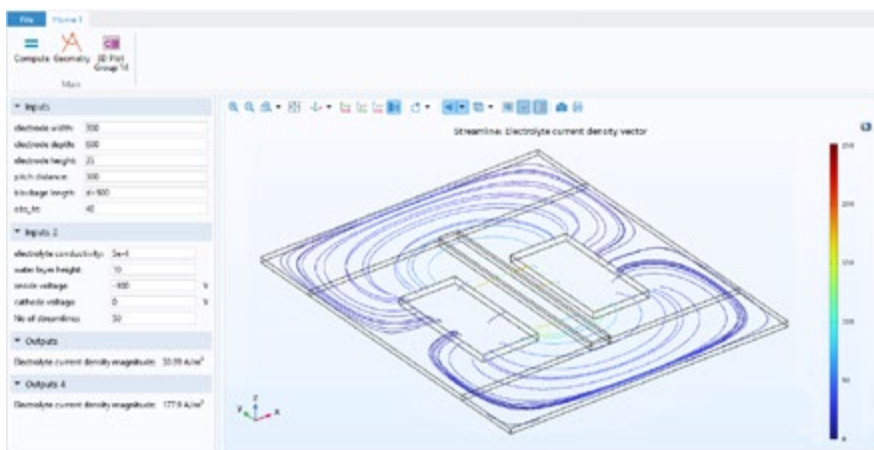

FIGURE 4 The UI of one of the simulation apps showing a streamline plot with inputs such as the cathode voltage and blockage length.

COMSOL, USA

IMPROVING BATTERY DESIGN FOR EVTOL AIRCRAFT WITH SIMULATION

Batteries for eVTOL aircraft need to deliver high power for efficient takeoff and landing, as well as high energy for the cruise period. To meet these demands, designers must consider the power–energy tradeoff of batteries and integrate a reliable battery management system into the overall design. Multiphysics simulation can be used to evaluate this tradeoff and consider all design requirements in a way that is comprehensive and saves time.

by NILOOFAR KAMYAB

In recent years, more and more organizations have announced their development of electric vertical take-off and landing (eVTOL) systems and, in some cases, are even showing previews of systems that are intended to hit the market in just a few years. As new design ideas emerge, there is one important question that needs to be asked: To keep up with the developments in eVTOL aircraft, what design requirements need to be considered for the batteries that power them?

Batteries used in transport technology need to be safe and durable and have high performance and quick charging times. Although electric batteries that meet these needs already exist on the market due to the rise in electric vehicles (EVs), there are notable differences in the performance needs for EV and eVTOL batteries. For instance, with eVTOL systems, the stages of flight need to be considered, as the battery cannot be so heavy as to hinder takeoff yet needs enough power to support vertical takeoff and landing as well as

(horizontal) cruising. In addition, an eVTOL battery needs to have a long cycle life and rapid charging capabilities so that it can be quickly recharged in the time between the aircraft landing and taking off again. Creating a safe battery that meets these demands requires evaluating the power–energy tradeoff, designing an optimal battery management system, and reducing the risk of battery degradation. Multiphysics simulation offers an efficient way to work through these steps and perform in-depth analyses at different scales.

» POWER-ENERGY TRADEOFF

In the context of eVTOL aircraft, it is essential to highlight the dual demands of high power for takeoff and landing, as well as high energy for sustained flight. Ideally, there needs to be a balance between power-optimized and energy-optimized cells in an eVTOL system. Power-optimized cells provide high power density and can deliver high current loads, which are imperative

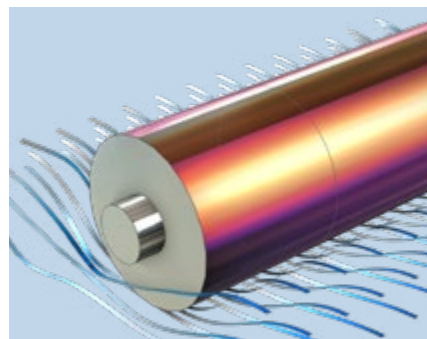

FIGURE 1 A cell scale and pack scale model in the COMSOL Multiphysics® software.

for rapid acceleration, takeoff, and maneuvering. They are critical during the takeoff and landing phases, when high bursts of power are required. In contrast, energy-optimized cells provide high energy density and can store more energy, translating to longer flight times and greater range. These cells are important for maintaining prolonged flight duration, ensuring the aircraft can travel significant distances without requiring frequent recharges.

The COMSOL Multiphysics® software can play a crucial role in evaluating and optimizing battery design to achieve the crucial balance between these dual demands. Performing studies such as rate capability analyses provides valuable insight into how batteries perform under varying charge and discharge rates. By simulating a range of different C-rates, engineers can evaluate factors like capacity retention and voltage stability (Figure 2), enabling them to predict how different battery configurations and materials impact performance under real-world eVTOL conditions. By adjusting parameters such as electrode thickness, electrode porosity, and electrolyte composition, engineers can optimize battery designs to strike a balance between power density and energy density and enhance the overall reliability, longevity, and safety of eVTOL battery systems.

In the software, the evaluation can be expanded to gain a deeper understanding of specific results and comprehensive insights into key aspects of the underlying phenomena occurring in the cells. For instance, if a significant capacity decrease occurs at a certain C-rate, designers can investigate the underlying cause by analyzing internal variables of the cell, such as the electrolyte salt concentration and the potential drop across it. Such detailed analyses can help designers understand why the capacity utilization decreases considerably with increased load. Or, if the goal is to compare two different battery designs, generating a Ragone plot (Figure 3) helps visualize how these batteries perform in terms of storing energy (energy density) versus delivering power (power density) under different operating conditions, enabling a timely comparison.

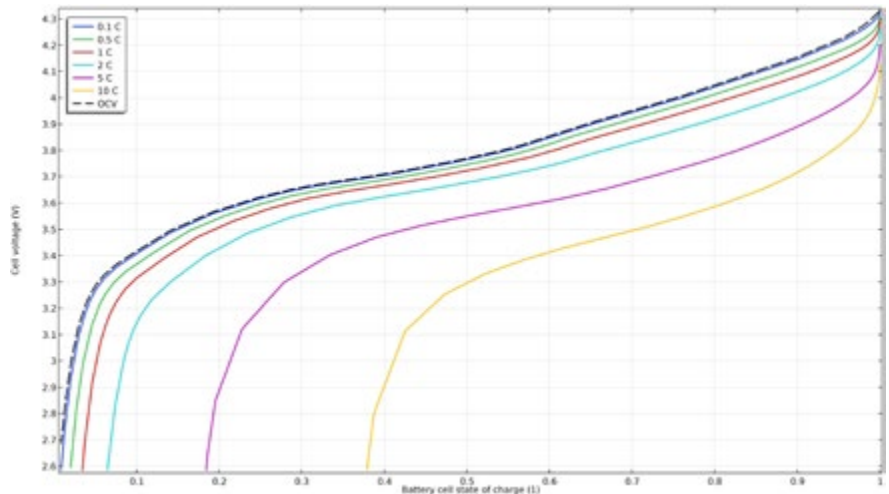

FIGURE 2 The cell voltage versus the state of charge (SOC) for various C-rates of an energy-optimized cell (solid lines) and the corresponding open-circuit voltage (OCV) versus SOC (dashed line).

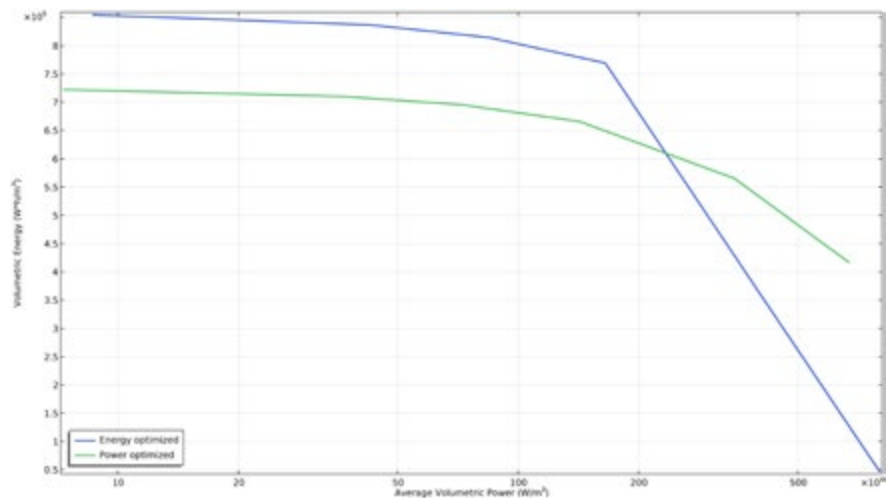

FIGURE 3 A Ragone plot depicting volumetric energy against average volumetric power, comparing a cell optimized for energy with one optimized for power.

» BATTERY MANAGEMENT SYSTEMS

All applications using batteries need a battery management system (BMS). The BMS continuously monitors critical performance parameters such as voltage, current, temperature, and state of charge (SOC) to keep a battery within safe operational limits, protecting it from conditions like overcharging, overdischarging, and overheating. It also balances the cells within a battery pack to ensure uniform performance

and extend the overall battery life. This information is communicated to users and operators in real time, keeping them well informed about the status and health of the battery systems.

As batteries operate, various degradation processes occur, such as mechanical degradation, the loss of active material, and electrolyte depletion. These processes lead to several unwanted effects that cause capacity loss in batteries. They diminish the battery's performance, reducing

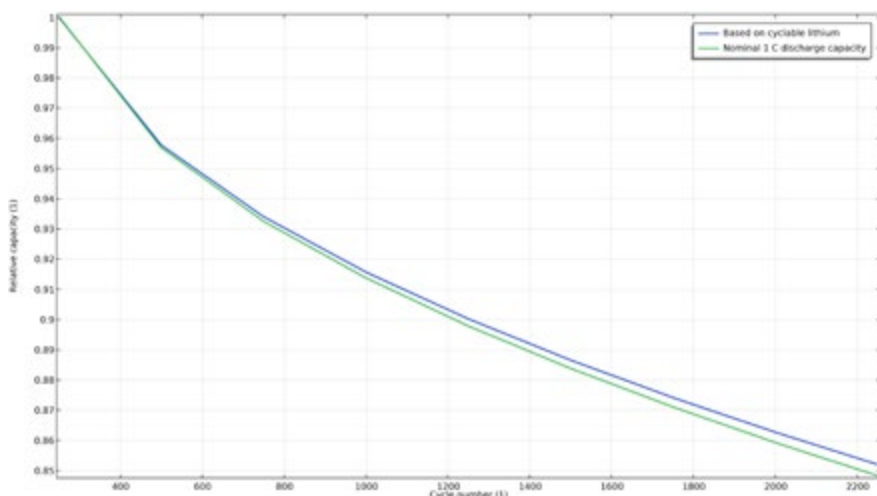

FIGURE 4 The relative capacity versus cycle number of an example model.

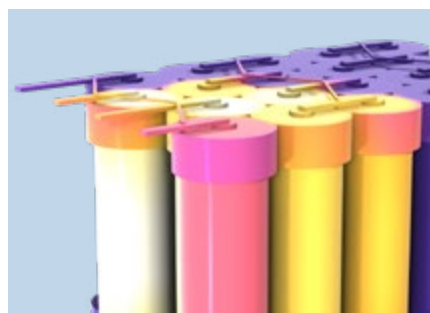

FIGURE 5 A model of thermal runaway propagation in a battery pack.

its ability to deliver power (power fade) and store energy (capacity fade) over time. Early detection of battery degradation helps mitigate risks like in-flight failures or power loss and assists operators in planning battery usage and maintenance. Tracking degradation metrics such as impedance, capacity retention, and voltage profiles during cycles via the BMS provides insight into the extent of degradation over time and ensures the safe, reliable, and efficient use of batteries in various systems.

In COMSOL Multiphysics®, conducting a dynamic degradation and life analysis enables the integration of diverse degradation mechanisms into a simulation. This approach facilitates the study of the evolution of parasitic processes over time, their impact on regular battery operation, and the resulting capacity loss. It also enables investigation of subsequent changes in

cell chemistry and the cell's structural integrity. For example, an aging model can be developed to simulate the formation of a parasitic solid-electrolyte-interphase (SEI) film on the negative electrode of a lithium-ion cell over 2000 cycles, resulting in irreversible loss of cyclable lithium (Figure 4). This model also captures the resistance of the growing SEI film as well as the effect of the reduced volume fraction on charge transport within the electrolyte.

Monitoring a battery's temperature is also critical for optimizing its performance, evaluating and preventing degradation, and ensuring safety. In a battery pack, if one cell overheats, the other cells in that pack and in connecting packs will follow suit, leading to battery failure and potential safety issues, such as fire. Looking at heat generation among cell packs can also guide decision-making regarding the setup of how the batteries will be housed in the eVTOL system. If the batteries are interconnected, there is an increased risk of all batteries malfunctioning while the system is in the air.

Using the COMSOL® software, a thermal analysis can be performed to identify hot spots and determine the maximum temperature threshold at which cells may overheat — providing designers with a better understanding of what design adjustments are needed to prevent thermal runaway. Additionally, engineers can simulate an individual battery cell experiencing thermal runaway due to abuse like short circuits

or excessive heating in order to forecast when and how the runaway will occur, as well as how quickly it will spread throughout the entire battery pack. The software can also be used to virtually test different cooling mechanisms and thermal management strategies.

» VERSATILITY OF COMSOL MULTIPHYSICS® FOR BATTERY DESIGN

Like with EVs, lithium-ion batteries are widely considered as the frontrunner battery choice for eVTOLs, but alternative technologies, such as solid-state batteries, sodium-ion batteries, and fuel cells, are also being considered. The Battery Design Module, an add-on product to COMSOL Multiphysics®, includes built-in features for modeling lithium-ion batteries and general battery and electrochemistry features for constructing a battery model for any chemistry, including sodium-ion and solid-state batteries. Additionally, the Fuel Cell & Electrolyzer Module offers specialized functionality for modeling fuel cells.

Depending on the purpose of the modeling, battery modeling in COMSOL Multiphysics® can be carried out at different scales, ranging from highly sophisticated microscopic models aimed at a detailed understanding of battery behavior to simplified, lumped models used for simulating battery packs integrated within larger systems, such as eVTOLs. The COMSOL® software also provides unique functionality for performing multiphysics analyses, facilitating a thorough examination of how electrical, thermal, and mechanical factors interact across these scales.

» EVTOL BATTERY SIMULATION TAKES OFF

Batteries for use in eVTOL systems need to achieve sufficient power-energy tradeoff, and multiphysics simulation offers a comprehensive and timely way to work through all of the design requirements. Reliable design software is especially important right now given the expected increase in eVTOL aircraft design in the aerospace & defense industry and the growing discussion around eVTOL aircraft for public transport (so-called "air taxis"). Before these aircraft take flight, suitable battery designs are needed. ☺

Pinggao Group, China

HIGH-VOLTAGE SWITCH INNOVATION FOR ELECTRIC POWER SYSTEMS

Simulation is being used at Pinggao Group to help ensure stable electric power transmission. The company uses multiphysics simulation, simulation apps, and digital twins to better understand and improve the design of electric power system components. The apps have been downloaded thousands of times throughout the company's engineering teams.

by RENJI HAO

Electric power systems are the foundation of modern society. These complex systems contain a variety of equipment used for electric power generation, transmission, transformation, and distribution, as well as for electric power overflow protection. High-voltage switches (Figure 1), the key components for the operation of a power system, are capable of switching or disconnecting circuits within a rated voltage range in order to distribute and control electric power according to the power consumption demands of different regions and equipment. They must not only withstand extremely high voltages and large current surges but also achieve

stable, long-term operation in order to maintain the normal functioning of the power grid.

The internal voltage of high-voltage switches can reach up to 1100 kV, and the switches must be able to cut off currents exceeding 100 kA in an extremely short amount of time. During the process of cutting off the current, an arc with energy up to 100 MW is generated, accompanied by various physical phenomena, such as discharge, heating, and ablation, posing significant challenges to the insulation design of high-voltage switches. Wang Zhijun, the director of the Institute of Basic Technology at Pinggao Group, said,

"Traditional design methods based on experiments are expensive and time consuming, with each experimental test requiring approximately 10 million RMB (~1.4 million USD) and lasting several weeks." Moreover, the measurement of electric signals is easily affected by the high voltage of the equipment, resulting in inaccurate results. These methods can no longer meet the demands of high-voltage switch R&D. To address these issues, Zhijun and his team at Pinggao Group have turned to simulation to improve processes and designs.

Pinggao Group Co., Ltd. is a subsidiary of the State Grid Corporation of China and an important member of China

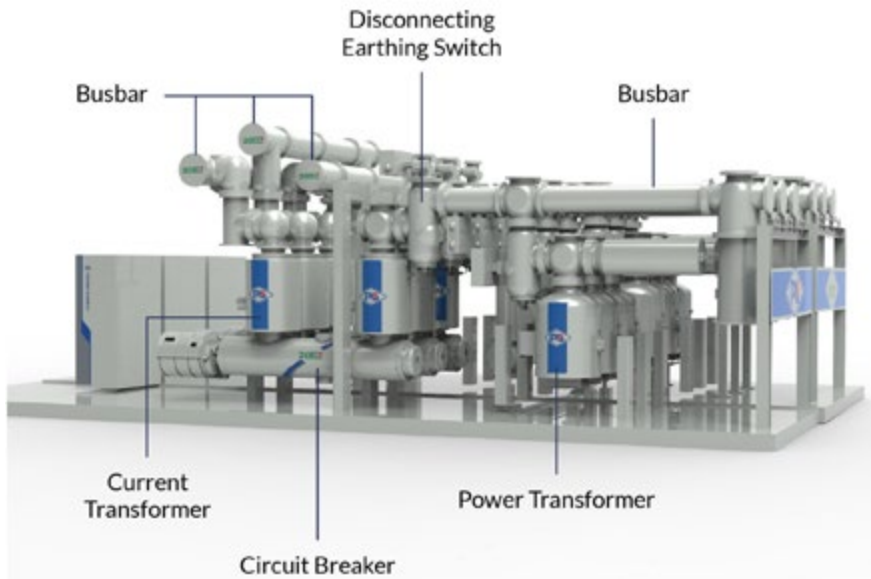

FIGURE 1 A gas-insulated high-voltage switch.

Electrical Equipment Group. Pinggao Group focuses on the development and production of high-voltage and ultrahigh-voltage electrical equipment. Different teams at the company use simulation to explore in depth the factors that affect the performance of high-voltage switches as well as to optimize switch designs and predict the operational status of equipment.

» OPTIMIZING HIGH-VOLTAGE SWITCH DESIGNS TO AVOID INSULATION FAILURE

During the long-term operation of high-voltage switches, the charged particles in the insulating gas and the carriers in the insulating material undergo directional movement under the influence of a DC electric field and end up accumulating on the surface of insulators and other components. When the aggregated charge reaches a certain amount, partial discharge phenomena may occur, resulting in insulation failure, which significantly affects the safe and stable operation of high-voltage switches.

With the COMSOL Multiphysics® simulation software, Pinggao Group identified DC insulation criteria applicable to different working conditions as well as areas of field strength concentration and insulation

weak points. This information is valuable in insulation design for DC equipment. A key aspect of gathering this information was looking at the physics phenomena involved in a DC insulation problem, and with the software, the team was able to assess multiphysics couplings

between electromagnetics, heat transfer, structural mechanics, and other physics phenomena. The team also used simulation to look at the electric field distribution on the disk insulator under DC voltage.

Based on this research, Pinggao Group developed the world's first 1100-kV SF₆-insulated wall bushing, which is used to isolate and protect DC cables when passing through walls, floors, or building structures. This wall bushing has been safely operating for 5 years and significantly improves the capacity, efficiency, and stability of power transmission systems.

In addition to the accumulation of charged particles, another cause of insulation failure in high-voltage switches is the inevitable generation of metal particles. These particles result from wear and tear that occurs during the installation of the high-voltage switch, thermal expansion and contraction of the cylinder that encloses different high-voltage switch components, and long-term operation. The movement of the particles under the combined effect of the electric field and the insulating gas flow field is extremely complex, difficult to predict, and challenging to observe with the

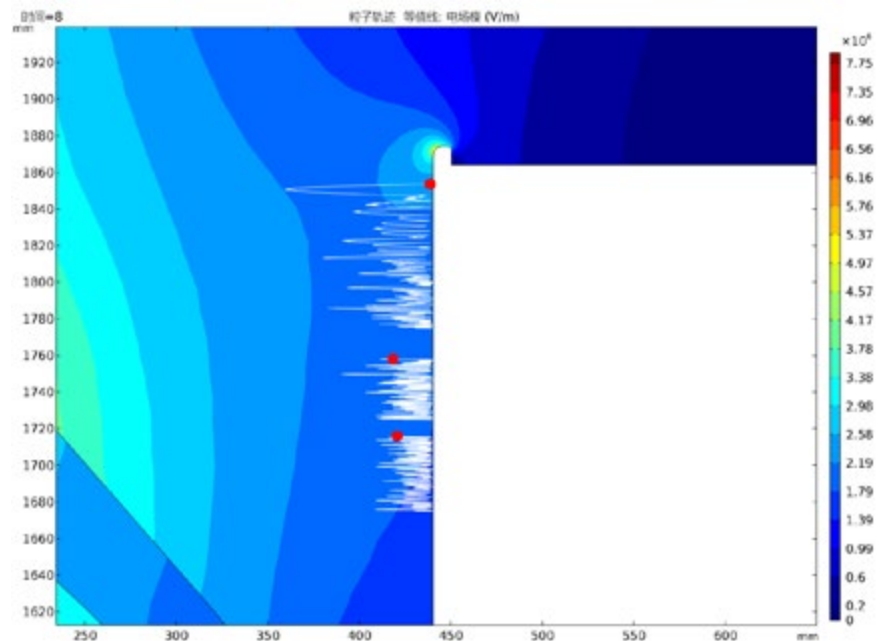

FIGURE 2 A plot showing the moving trajectory of metallic particles placed near a particle trap.

"The extensive experience and techniques we have accumulated over the years in product development are integrated into the simulation apps, helping eliminate knowledge barriers and difficulties in the simulation modeling process."

— WANG ZHIJUN, DIRECTOR OF THE INSTITUTE OF BASIC TECHNOLOGY AT PINGGAO GROUP

naked eye. If these particles adhere to the insulator surface, it will lead to changes in the surrounding electric field, triggering gas breakdown and affecting the insulation performance of the insulator. To address these issues, Pinggao Group used multiphysics simulation to evaluate the forces acting on the particles and their moving trajectory (Figure 2).

To better understand the forces acting on the particles, the team considered the factors of gravity, SF₆ gas resistance, Coulomb force, electric field gradient force, and friction. The jumping direction and displacement of the particles were simulated in order to investigate the relationship between particle mass, shape, and jump height. This information provided guidance for the design of a particle trap (Figure 3), which is used to minimize the impact of metal particles on the insulation performance of high-voltage switches.

The team created multiple models for different particle trap designs, and the optimized trap design has since been completed and applied to Pinggao Group's gas-insulated transmission line (GIL) products. GILs are used for power transmission subject to harsh conditions like high altitude, low temperature, and long transmission distance because of their advantages of large transmission capacity, low power loss, compact structure, and high reliability.

» SIMULATION APPS BENEFIT THE ENTIRE ORGANIZATION

In the process of using multiphysics simulation for high-voltage switch product design, Pinggao Group found that the development and maintenance of multiphysics simulation models require a deep understanding of the underlying physical principles of the products and the numerical methods used in simulations. Additionally, team

members required training on how to use simulation, and design optimization required the simulation personnel to perform modeling calculations that could be repetitive. To help simplify design processes and make it easier for team members to understand and use simulation, Pinggao Group decided to build its own custom simulation apps based on its existing models, which take the form of easy-to-use user interfaces with a set number of parameters.

Pinggao Group has developed more than 50 simulation apps using the Application Builder in COMSOL Multiphysics®. The apps were compiled into standalone executable files using COMSOL Compiler™, which enables different teams to run the apps independently. The customized apps are simple, user friendly, and enable users to quickly verify the feasibility of a new design by inputting a small number of parameters and obtaining simulation results. The apps cover a wide range of critical technical areas, including electromagnetic heating analysis, insulation performance evaluation, mechanical design, and failure analysis.

One of the apps that Pinggao Group created is used to calculate the temperature change that occurs in the busbar of a high-voltage switch because

of electromagnetic heating (Figure 4). By inputting geometric dimensions, material properties, and operating conditions into the app, the team can compute results such as the magnetic flux density, current density, temperature distribution, and airflow velocity distribution. The temperature rise of the busbar under operating conditions can be simulated to determine whether the busbar structure meets the temperature rise requirements.

"By automating the preparatory and results visualization processes, we can significantly reduce labor requirements and speed up product development," said Zhijun. "The extensive experience and techniques we have accumulated over the years in product development are integrated into the simulation apps, helping eliminate knowledge barriers and difficulties in the simulation modeling process. This makes it easier for engineers and technicians across different departments within the organization to use simulations to validate the design, manufacturing, and operation and maintenance of products."

Pinggao Group has established an internal web browser, called "Simulation App Store", where engineers can easily and quickly access the apps, upload and download simulation data and results, and share project information within teams. In the web browser, the simulation apps are categorized based on different design parameters, such as electric field, power, and stress, which helps users in different departments quickly find suitable, customized simulation apps. Currently, the simulation apps have been downloaded thousands of times throughout the company's engineering teams.



FIGURE 3 A metal particle trap designed by Pinggao Group.

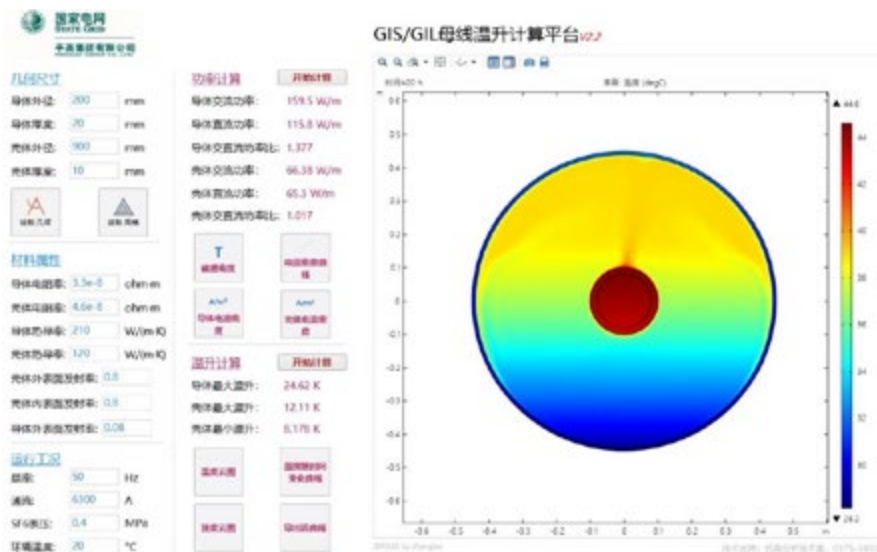

FIGURE 4 The High-Voltage Switch Busbar Electromagnetic Heating Simulation app built by Pinggao Group, showing the input options and temperature of a busbar example.

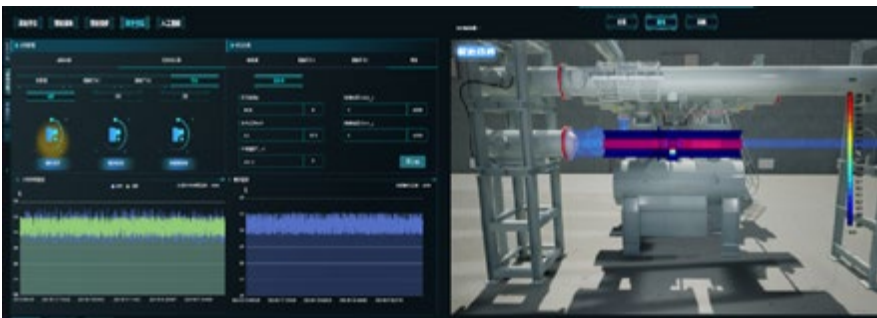

FIGURE 5 The application of multiphysics simulation for a digital twin used at Zhongzhou Converter Station. Shown is the interface of a digital converter station platform developed by Pinggao Group.

» DIGITAL TWINS OF REAL-WORLD ELECTRIC SYSTEMS

When it comes to power equipment, relying solely on historical data to predict and analyze the future performance of the equipment is inaccurate due to the uncertainty of load conditions and the diversity of operating environments. Moreover, during the operation of power equipment, different physical fields, such as thermal, electric, and magnetic fields, interact with each other, and the effects of those interactions can be difficult to predict. Multiphysics simulation can be combined with online monitoring data to build high-fidelity

models that can then be turned into digital twins that are synchronized with the power equipment and updated in real time.

A digital twin is an interactive mapping model that integrates information technologies such as sensing, computing, and simulation to achieve full-scale and full-life-cycle interactions between physical and virtual spaces. Digital twins can be used to analyze the changes in physical objects and thus offer a way to better monitor them, predict their behavior, and optimize them so that they meet functional and application needs.

With the COMSOL® software, Pinggao Group has successfully achieved a digital

twin model with full-life-cycle digital management and state inversion for metal-enclosed gas-insulated switchgear (GIS) disconnect switch equipment, which is a commonly used type of high-voltage switch. Pinggao Group is able to use the digital twin to diagnose and evaluate the state of high-voltage switches. For instance, when an abnormal state occurs, it is possible to locate the problem and identify the causes via the digital twin. These models have been deployed to the Zhongzhou UHV Converter Station, which is part of an electricity transmission system in China.

The digital twin model of the high-voltage switch collects real-time operational data from the power equipment via sensors, and this data is automatically used as input in a simulation app called "GIS Isolation Switch Fast Simulation App with Local Overheating State Inversion Function". As a result, the simulation time of the temperature and electric fields in high-voltage switches has been reduced to seconds. A digital twin model of the GIS disconnecting switch is shown in Figure 5, with real-time operational data on the left and the simulation results on the right. The simulation results are used to analyze and monitor the operational status of the power equipment, enabling state inversion and the identification of abnormal operating conditions.

» CONTINUING THE USE OF SIMULATION AT PINGGAO GROUP

Pinggao Group plans to continue integrating multiphysics simulation into its development processes in order to help product designers develop high-voltage switches with better performance.

"For the critical issues encountered during the development of high-voltage switches, we have been able to find corresponding features and solutions in the COMSOL® software, which has provided significant support for our development work," said Zhijun. "The simulation apps have further enhanced the application and value of simulation technology within the organization."

Pinggao Group is also going to explore further applications of simulation in the development of renewable energy applications, including for energy storage and integrated energy systems. ☺

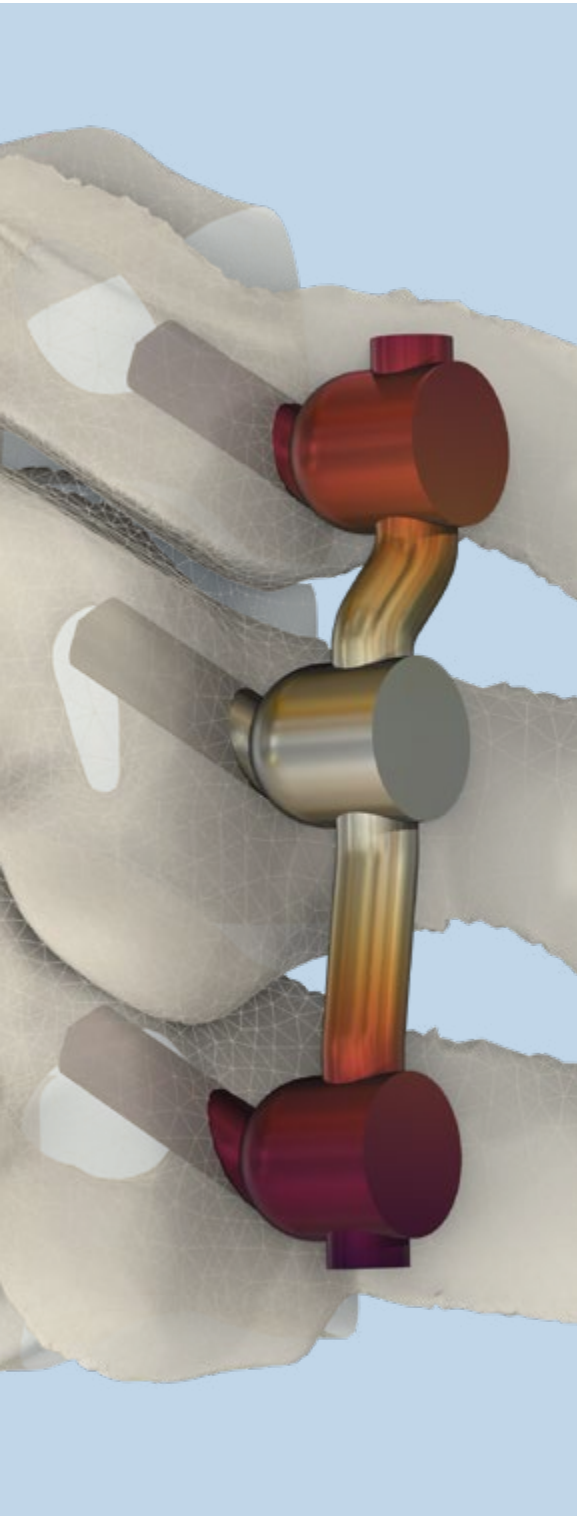

FIGURE 1 Temperature increase of biological tissue surrounding a passive conductive implant due to RF heating during MRI.

COMSOL, USA

MEDICAL DEVICE DESIGN WITH MULTIPHYSICS SIMULATION AND AI SUPPORT

Simulation can be used in the design of medical devices to predict device behavior and potential issues, such as unwanted thermal behavior that could potentially harm patients. Moreover, combining simulation tools with AI tools can help streamline processes.

by DIXITA PATEL

Engineers and researchers continue to advance medical technology by finding innovative solutions for diagnosis, testing, and treatment. Computational modeling and simulation (CM&S) is playing an increasingly important role in these solutions and such efforts are supported by the FDA for evaluating safety and predicting clinical outcomes.

By using simulation, engineering teams can study how a device behaves before building physical prototypes, making it possible to identify potential risks, explore design options, and make more informed decisions earlier in development. Simulation is particularly valuable in patient-specific applications, where physical testing can be both time-consuming and costly. As simulation becomes more integrated into development processes, it can be used with emerging technologies, such as AI, while still complementing traditional approaches.

» UNDERSTANDING THERMAL RISK

Thermal effects are a good example of how simulation can be used to evaluate safety in medical devices. In many cases, electromagnetic fields interacting with biological tissue can generate heat that needs to be carefully assessed in order to avoid unintended damage. For instance, in procedures such as RF ablation, heating is intentional and must

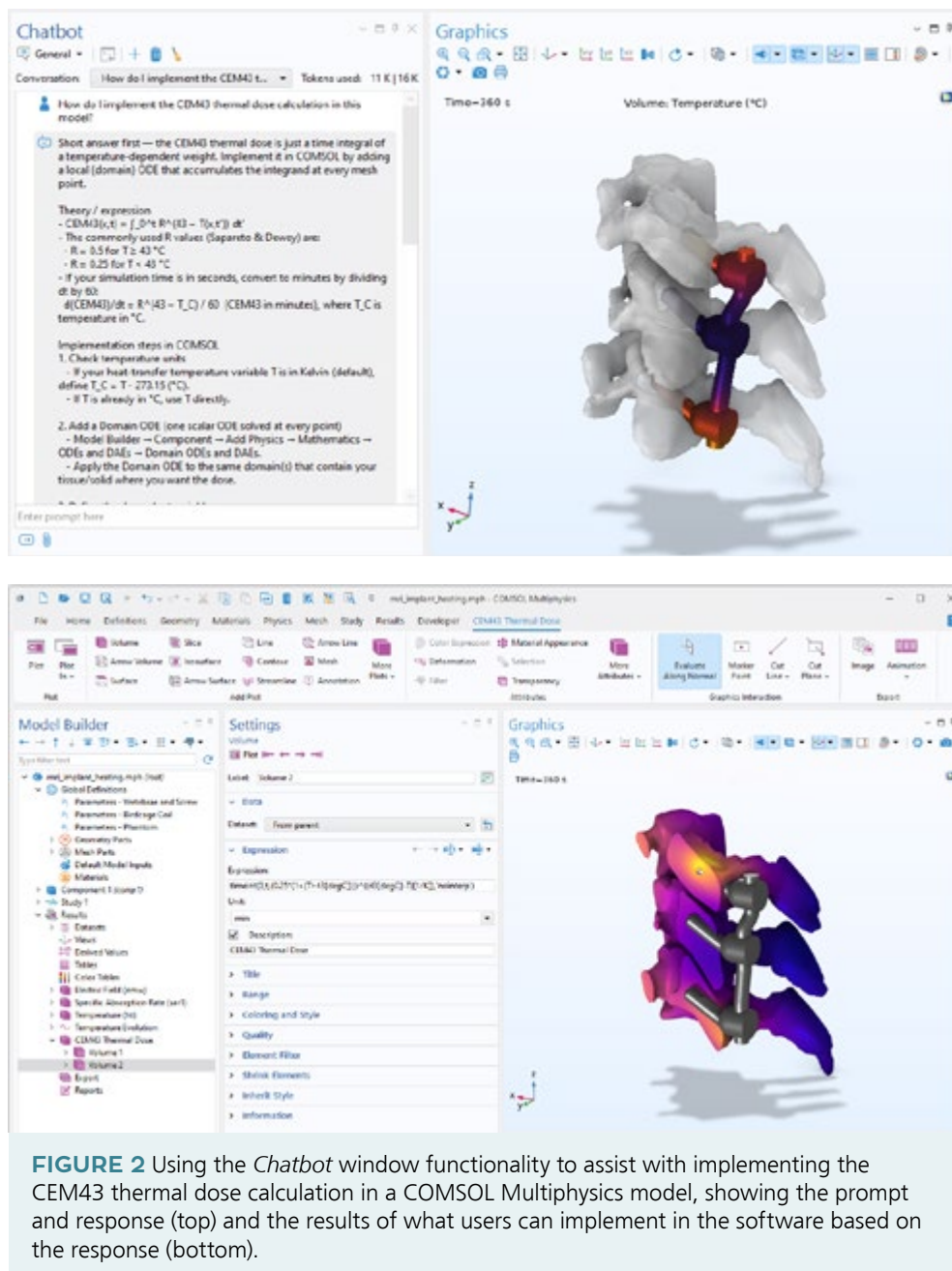

FIGURE 2 Using the *Chatbot* window functionality to assist with implementing the CEM43 thermal dose calculation in a COMSOL Multiphysics model, showing the prompt and response (top) and the results of what users can implement in the software based on the response (bottom).

be controlled. In other environments, such as inside an MRI, implants can experience unintended heating that also needs to be evaluated.

These situations involve several coupled physical effects. Electromagnetic fields, heat transfer, and tissue properties are all interacting, making the problem difficult to study with testing alone. Simulation helps designers

analyze these interactions in a controlled way across many scenarios. Using the COMSOL Multiphysics® software, engineers can model these effects and better understand how a device will behave under realistic conditions.

Metrics such as cumulative equivalent minutes at 43°C (CEM43) take both temperature and exposure time into account and are

commonly used to assess potential tissue damage. Including these metrics in a simulation makes it easier to see how the predictions translate into potential risk. For example, when modeling spinal implants in an MRI environment, simulation results can show that RF fields can become locally concentrated near conductive components such as rods and

screws, which could lead to increased heating in nearby tissue. With simulation software like COMSOL Multiphysics®, it is not only possible to visualize these effects but also quantify them using metrics such as CEM43, helping engineers make more informed design decisions.

» EXTENDING SIMULATION WORKFLOWS WITH AI

In COMSOL Multiphysics®, the *Chatbot* window makes it possible to connect the software directly to large language models such as OpenAI™ GPT, Google Gemini™, DeepSeek™, or on-premises solutions. Because this AI functionality is fully embedded in the COMSOL Desktop® environment, there is no need to switch between external tools.

The *Chatbot* window supports tasks such as implementing modeling calculations and providing guidance on questions related to COMSOL Multiphysics®, while also helping to address specific modeling challenges. For instance, when working through complex problems, such as implementing calculations like CEM43, the *Chatbot* window can suggest formulations or help structure the required expressions.

AI-generated suggestions should still be reviewed during the modeling process, but when used carefully in combination with simulation, AI-assisted workflows can significantly simplify complex modeling tasks, reduce setup time, and allow engineers to focus on interpreting results and refining designs. This approach can also speed up development and support smarter decisions, all without compromising safety or performance. ©

United Kingdom Atomic Energy Authority
and Demcon Multiphysics, United Kingdom

A STEP IN THE RIGHT DIRECTION: MODELING AC LOSSES IN A TOKAMAK DESIGN

STEP Fusion, led by UK Fusion Energy Ltd., worked with Demcon Multiphysics to calculate expected AC losses in the fusion system for the Spherical Tokamak for Energy Production program.

by **JOSEPH CAREW**

Each passing year brings the world closer to unlocking grid-scale fusion energy. Organizations are funneling significant resources into fusion reactor designs to make this goal a reality. One such organization, UK Fusion Energy Ltd., a subsidiary of the UK Atomic Energy Authority (UKAEA), is leading the Spherical Tokamak for Energy Production (STEP) program, which aims to deliver a prototype fusion energy plant in the early 2040s. STEP is based on a high-performance spherical tokamak design enabled by rare-earth barium copper oxide (ReBCO) high-temperature superconducting (HTS) magnets. These magnets allow substantially higher operating magnetic fields than conventional conductors, increasing fusion power density while providing greater design flexibility for a power-plant-scale reactor configuration.

However, high-field operation imposes stringent requirements on magnet performance and thermal management. In particular, accurately quantifying AC losses in the HTS magnet system is a key design challenge. During plasma initiation, the charging and discharging of the central solenoid (CS) and poloidal field (PF) coils generate rapidly varying

electromagnetic fields throughout the magnet system. These ramping processes give rise to AC losses within the CS and PF coils themselves. At the same time, the time-dependent magnetic fields produced by these coils induce screening currents in the toroidal field (TF) cables. Although the TF coils operate with direct current (DC), their exposure to transient background fields leads to

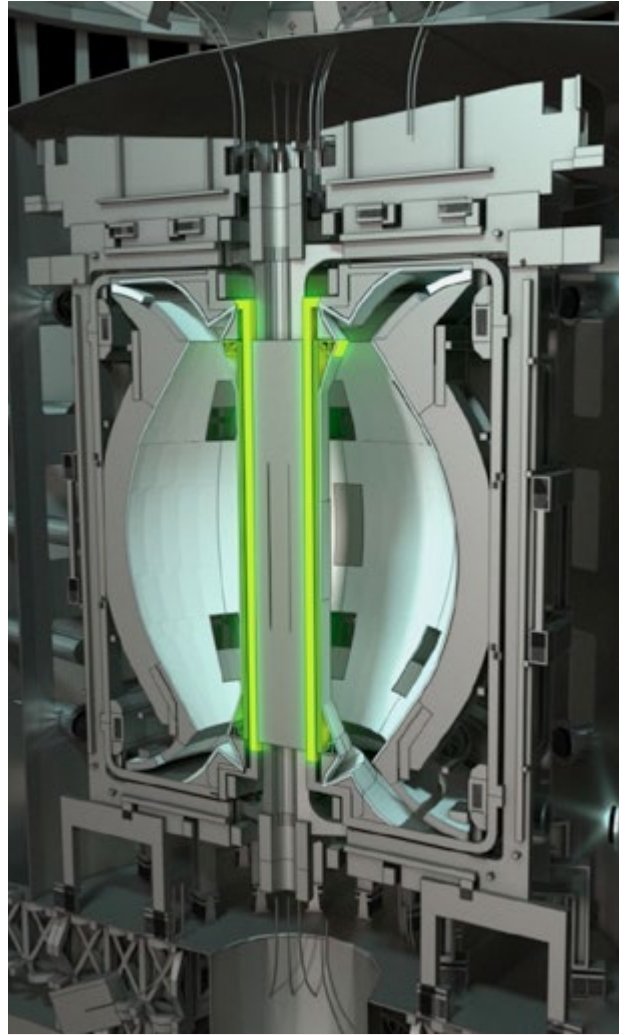

FIGURE 1 Illustration of the cross-section of the STEP tokamak concept.

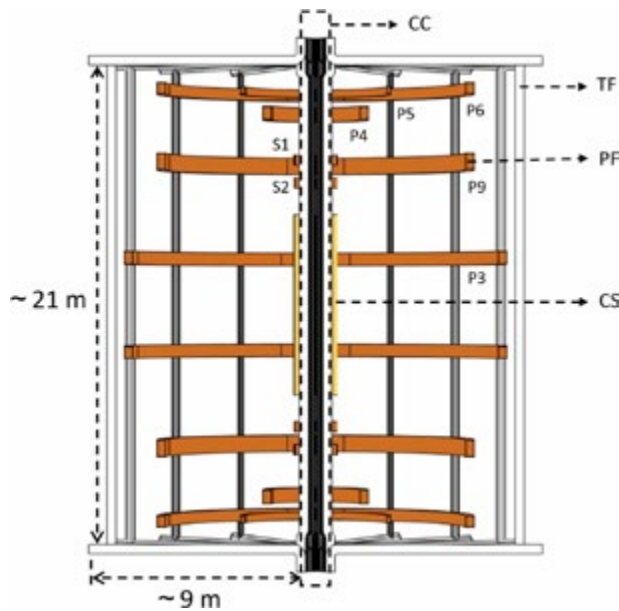

FIGURE 2 A cutaway diagram of the STEP magnets showing the 16 TF coils; the PF coils (labeled S1, S2, P3, P4, P5, P6, and P9); and the CS. The center column is labeled CC.

additional AC losses that must be understood and controlled to preserve thermal margin and ensure reliable operation.

To address this challenge, STEP Fusion worked with Demcon Multiphysics to develop models of all the CS, PF, and TF coils and evaluate the resulting electromagnetic losses under representative operating scenarios.

» STEP'S MAGNET SYSTEM

STEP's magnet system (Figures 1 and 2) is designed to include 16 TF magnets, each containing 40 turns. Each of these turns consists of a vertically stacked tape (VST) cable that contains 230 individual HTS tapes. The coils work together to initiate and confine the plasma. The CS induces the plasma current, while the TF and PF coils collectively control the plasma's position and shape.

"With a high field, we can increase fusion power density and improve the efficiency of

a spherical tokamak power plant, which can help reduce costs and support a more sustainable fusion energy system. That is a strategic target of the STEP program and why we chose to use the HTS magnets," said Jiabin Yang, a principal engineering analyst who works on the STEP program. "Importantly, the fusion power density in magnetic confinement systems increases strongly with magnetic field strength, following a high-order scaling with the field, and the recent development of HTS tapes capable of operating at such high fields has been a key enabler for advanced spherical tokamak concepts."

AC Losses in Magnets

AC losses arise from time-varying electromagnetic fields that induce currents and magnetization, posing a significant hurdle because they create localized heating in magnets, shrink the thermal margin, and increase

quench risk. The losses fall into three categories: hysteresis, coupling, and eddy current loss. Hysteresis losses arise in superconductors under time-varying electromagnetic conditions, such as changing magnetic fields or transport currents. Coupling losses result from currents induced between electrically connected superconducting and normal conducting elements. Eddy current losses occur in normal conducting components due to induced closed-loop currents, with all mechanisms ultimately dissipating energy as heat. AC losses arise during the plasma initiation phase, in which a quick discharge of the CS (within 0.37 s) provides the inductive drive for plasma current. The ramping of the CS and PF coils generates time-varying magnetic fields throughout the magnet system, giving rise to AC losses both within the CS and PF coils but also in the TF coils (despite their DC operation), mainly through screening currents within the HTS cable. In the center column, the inner limbs of the TF coils passing through the CS, where

the magnetic flux density reaches its highest values (up to ~20 T), are therefore particularly affected. Using an assumed current profile (Figure 3), Yang, multiphysics engineer Rien Wesselink of Demcon, and their respective teams tested the distribution of hysteresis losses and eddy current losses in one of the TF limbs formed from HTS cables.

» SIMULATION METHODOLOGY

When modeling the AC losses, STEP and Demcon used a multilevel simulation strategy tailored to different parts of the magnet system.

CS and PF Coil Modeling

The losses in the CS are determined through a 2D axisymmetric finite element model (Figure 4). Although the field from the TF coils is strictly not axisymmetric, a good estimation can be made by taking a conservative cross section of the TF field and imposing that as a background field. The magnetic field from the CS and PF is then imposed as a background field in a 2D planar infinitely long model used to simulate the AC

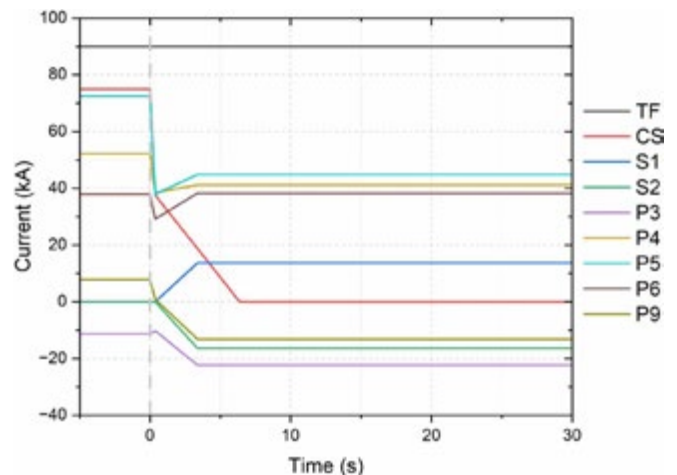

FIGURE 3 The assumed current profile is consistent with STEP's current operational design, but it will be subject to extensive modification during the design iteration process.

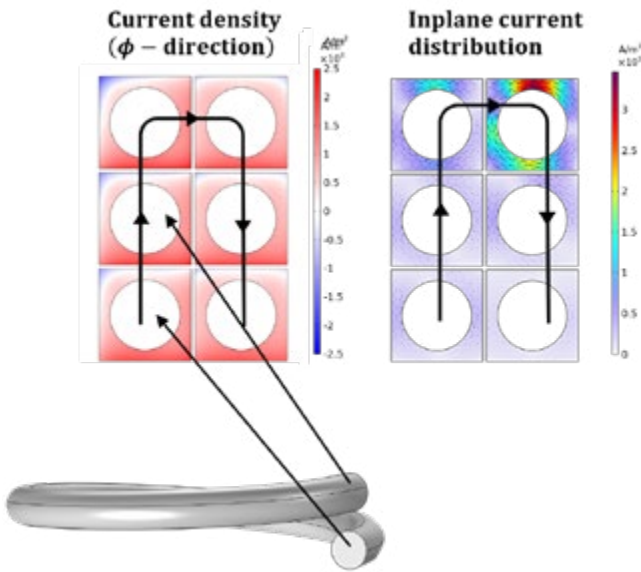

FIGURE 4 A 2D axisymmetric model was used to simulate the AC losses in the CS, and the additional losses arising from in-plane currents (which are neglected by default in the 2D axisymmetric model) were also evaluated.

losses generated in the inner TF limb.

TF Coil Modeling

Demcon then modeled the AC losses in the TF conductors, including hysteresis and eddy current contributions, using a 2D planar model. For this modeling, the researchers needed a formulation method that was able to accurately quantify the different induced currents throughout the geometry. For this reason, Demcon used an H-H0- ϕ formulation (a method that works around the need for a finite conductivity value in nonconducting domains) to model the magnetic properties of the superconducting materials. This approach splits the computational domain into conducting and nonconducting domains in order to optimize the simulation and to determine the energy losses along the TF magnet center column limb.

"We used the H-H0- ϕ formulation, which we

implemented into COMSOL Multiphysics[®]," Wesselink said. "There are two interfaces, the *Magnetic Field Formulation* (MFH) interface and the *Magnetic Fields, No Currents* interface, that we coupled together. The advantage of this approach

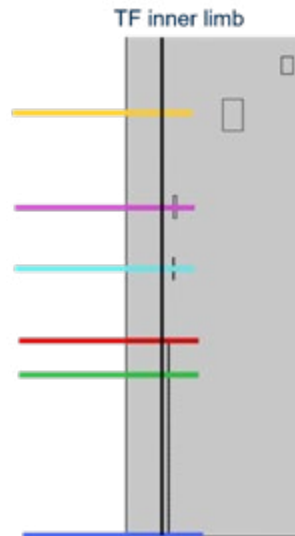

is that, compared to just the H formulation, you can have domains with zero conductivity."

While one could use 3D simulations to investigate the losses in the TF limbs in the center column (Figure 5), Yang, Wesselink, and their respective teams found these simulations to be quite time-consuming to set up, mesh, and run. Instead, a computationally efficient 2D cross-sectional approach was adopted. Multiple cross sections were evaluated along the length of the TF inner limb, and the total losses were obtained by integrating the results, thereby capturing the longitudinal variation without requiring a full 3D model.

"We assumed that the fields and currents varied slowly in the z direction (along the central axis of the tokamak), so we can take multiple 2D (xy) cross sections at different z-locations," Wesselink said. "Then we added the background fields from the CS and PF coils that were extracted from a simplified 2D axisymmetric calculation."

Estimating the Coupling Losses in TF

In STEP's TF cables, ReBCO tapes are stacked together, and this is an area that may exhibit nonnegligible coupling losses. The teams used a 3D resistive coupling model to calculate these losses. Figure 6 shows the different B-field components of the CS and the corresponding coupling currents they would induce in the TF coil conductors. Analytic estimations of these currents result in the conclusion that these are negligible contributions in the overall AC losses picture.

Yang's and Wesselink's teams verified the analytical estimations mentioned above with 3D calculations (Figure 7) that approximated the tape stack as a perfect conductor in the directions parallel to the tape and a normal conductor in the direction perpendicular to the tape. They found that the estimates were largely correct but that the eddy currents in the copper support are relevant.

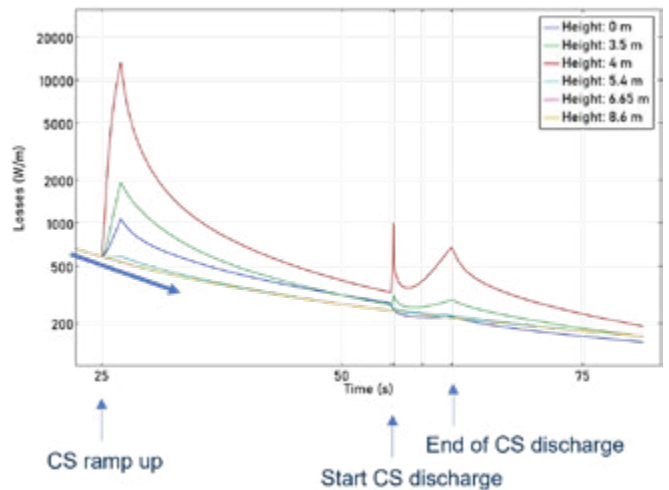

FIGURE 5 Based on the magnetic field distribution and its variation inside the center column, calculation points were selected along the TF limbs, and the total losses of the TF were then estimated by integration.

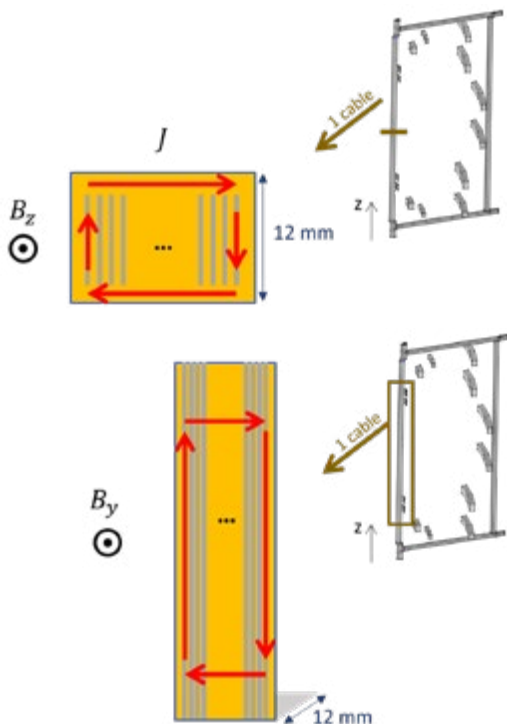

FIGURE 6 The B-field components of the CS, and the corresponding coupling currents they induce in the TF coil conductors.

» **LOOKING INTO THE THERMAL EFFECTS OF AC LOSSES IN TF**

All of this modeling and simulation pointed to the hysteresis losses in the ReBCO tapes being the dominant source of AC loss in STEP. These losses are localized around the ends of the CS magnet and the S1 PF magnet near the center column, and they scale with the magnetic field ramp rate. These losses, as predicted, will result in temperature increases.

"It costs an enormous amount of power to cool these fusion systems," Wesselink said. "All these losses require more input power for the cryogenic cooler."

Thus far, STEP and Demcon have completed a preliminary estimation on the temperature rise that can be expected within the TF. The temperature

distribution, based on the calculated hysteresis, eddy current, and coupling losses at representative positions, can be seen in Figure 8.

The teams found that the temperature rise associated with the AC losses in TF is sufficiently low and that additional mitigation such as twisting or transposition

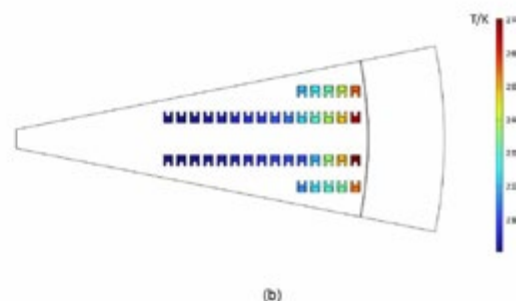
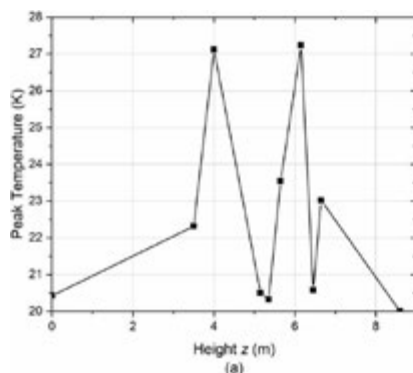

FIGURE 8 The peak temperature of the inner TF limb at different heights (a) and the peak temperature distribution across the coil at $z = 6.15$ m (b).

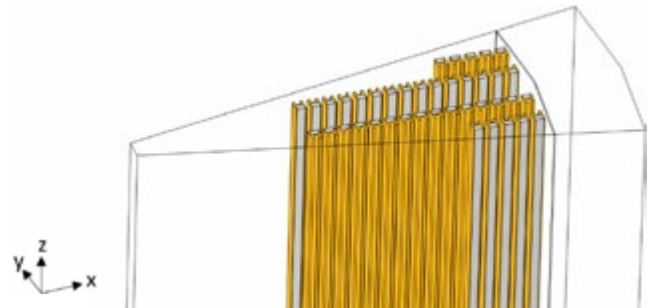

FIGURE 7 A schematic of the 3D model of a TF coil inner limb segment, which the engineers used for determining coupling losses.

is not required. For these reasons, they could use a simpler TF cable design that improves the manufacturability and efficiency of the HTS cables while keeping temperature rise within acceptable limits.

» **MOVING FORWARD WITH STEP**

The STEP program is well underway as its designers and engineers take on the numerous challenges associated with fusion power. In support of this effort, UK Fusion Energy Ltd. is continuing to work with Demcon Multiphysics to gain insight into the complex systems and phenomena and adjust the tokamak design accordingly.

The teams are currently working on 3D quench simulations of STEP's TF coils. These simulations are designed to evaluate potential quench protection strategies. To keep these calculations tractable, the respective teams have developed a new method (also implemented in COMSOL®) to approximate all the cables as lines. Thus far, simulation has been an integral part of that journey, and according to Yang and Wesselink, it will continue to be in the future. ☺

ACKNOWLEDGEMENT

This work has been funded by STEP Fusion, a major technology and infrastructure program led by UK Fusion Energy Ltd., which aims to deliver the UK's prototype fusion power plant and a path to the commercial viability of fusion.

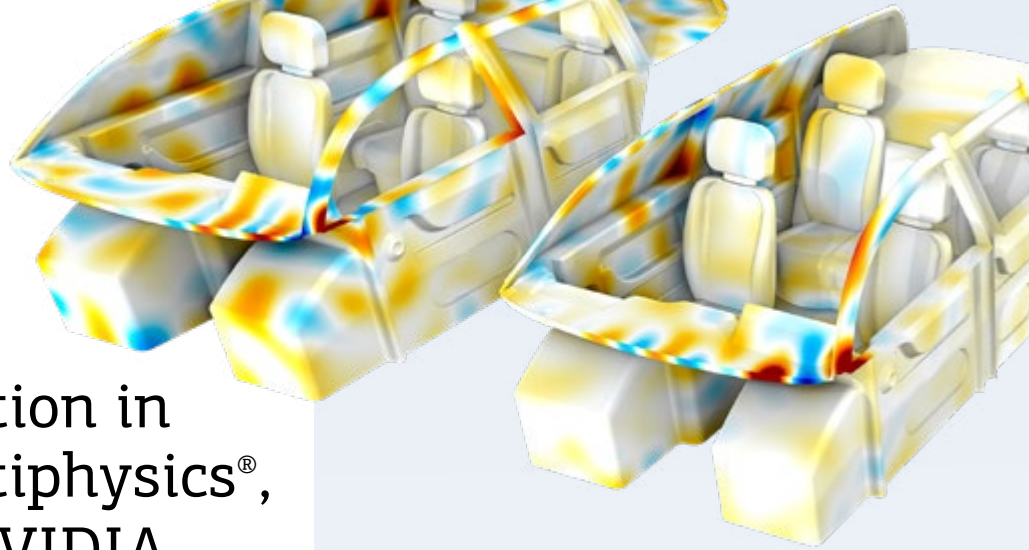

GPU Acceleration in COMSOL Multiphysics®, Powered by NVIDIA

by STEVEN COLLINS

Accurately modeling real-world behavior often requires multiphysics couplings, but these couplings can be computationally expensive, causing CPU-based solvers to become bottlenecks. The COMSOL Multiphysics® software supports NVIDIA GPU acceleration for direct sparse solvers, helping to alleviate these bottlenecks.

Thanks to the NVIDIA CUDA® direct sparse solver library (NVIDIA cuDSS), the software is able to leverage the high memory bandwidth and massive parallel architecture of NVIDIA® GPUs for multiphysics analysis. Support for NVIDIA cuDSS is now fully integrated into the standard solver framework, enabling COMSOL users to take advantage of NVIDIA GPU acceleration for existing models without needing to make changes to the underlying physics settings.

Additionally, multiphysics models can be run on a single GPU or in multi-GPU settings. Together, these capabilities make it much quicker to solve large, sparse systems — for many simulations, what once was left to run overnight can now be computed in just a few hours.

Another use case that's particularly well suited for harnessing GPU support is time-explicit pressure acoustics simulation. When running this type of simulation, users can avoid having to solve large linear systems at each time step by instead employing explicit time-stepping methods that rely on repeated vector operations and local element updates. These operations are highly parallelizable and map efficiently onto GPU hardware.

The process of generating deep-neural-network (DNN) surrogate models, which approximate high-fidelity numerical simulations, also benefits greatly from GPU-enabled enhancements, as training these networks requires repeated evaluation of large datasets and many optimization cycles.

Recent versions of COMSOL Multiphysics also include support for NVIDIA GPU acceleration in custom simulation apps — which users can build with set parameters and deploy to collaborators in order to extend the benefits of simulation-based decision making. For apps that rely on a full model or need verification against one, GPU-accelerated solvers significantly reduce turnaround time for computationally demanding analyses.

NVIDIA, CUDA, and RTX are trademarks and/or registered trademarks of NVIDIA Corporation in the U.S. and/or other countries. Intel, the Intel logo, Intel Core, Pentium and Xeon are trademarks of Intel Corporation in the U.S. and/or other countries.

BENCHMARK MODELS

Benchmarking multiphysics models with NVIDIA cuDSS has demonstrated speedups of up to five times or more compared to CPU-based direct solvers.

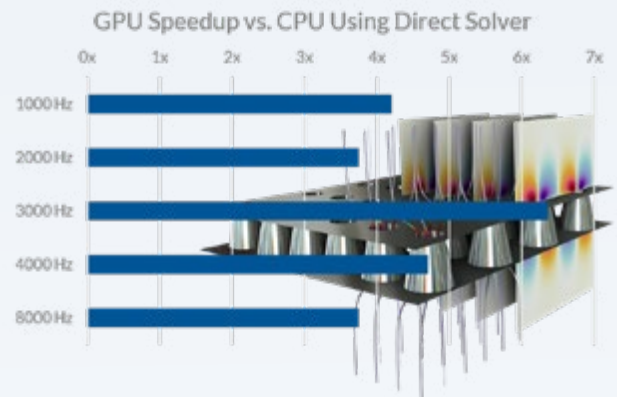

Benchmarking for model sizes between 0.9 and 4.5 million degrees of freedom (MDOFs) showed up to 6x speedup when solved with NVIDIA cuDSS on four NVIDIA® H100 GPUs compared to a dual Intel® Xeon® Platinum 8260 system.

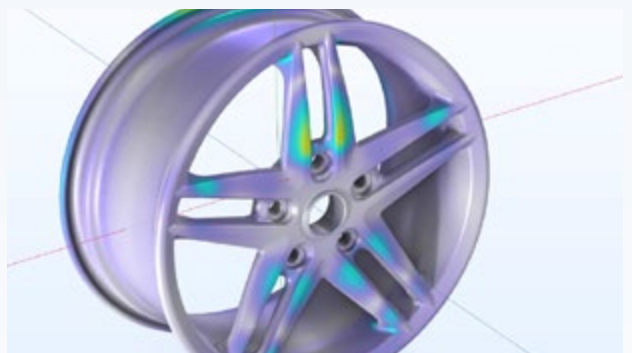

A GPU-based solve on an NVIDIA RTX™ 5000 Ada Generation GPU achieved a 2x speedup compared to a CPU-based solve on an Intel® W5-2465X processor.